

**Precision Lock-in Amplifier**

**9503SC      9503D-SC**

**9503C        9503D-C**

**9503          9503D**

This handbook is supplied for use with instrument model 9503.SC... serial no. 1011.

The Company maintains a policy of constant product improvement, as the components available and state of the art advance. This may lead to detail alterations in specification, operating procedure, or technical description. Thus handbooks should be used for the instrument with which they are supplied.

BROOKDEAL ELECTRONICS LTD., DONCASTLE HOUSE,  
DONCASTLE ROAD, BRACKNELL RG12 4PG,  
 AN EG&G COMPANY BERKSHIRE, ENGLAND

Telephone	Bracknell (0344) 23931
Telex	847164
Cables	Brookelec

index

		page
1	introduction	1
2	specification	2
3	basic operating instructions	9
4	system description	15
5	facilities & detailed operating instructions	21
5.1	power	21
5.2	checks using the function check facility	21
5.3	signal channel	25
5.4	response modes	33
5.5	reference channel	38
5.6	demodulator and output	41
5.7	option oscillator 5012F	47
5.8	option omniphase 5042	48
5.9	option ratiometer 5047	49
5.10	option noise measurement unit 5049	50
5.11	option installation instructions	51
5.12	points to watch	52
5.13	options, mod 10, 11, 13, 14	54
6	fault finding guide	56
7	parts list	65
	circuit diagrams	82

index of illustrations

		page
	photograph of the 9503SC	facing 1
	photograph of the 9503D	facing 1
	noise figure contours	3
fig 1	basic block diagram	15
fig 2	9503SC block diagram	18
fig 3	internal arrangement, block schematic	56
fig 4	inside the 9503SC	57
fig 5	reference monitor output waveforms	60
fig 6	phase splitter voltages	63
fig 7	demodulator waveforms	64
fig 8	switching and wiring diagram (9503)	82
fig 9	switching and wiring diagram (9503SC)	83
fig 10(a)	preamplifier board component layout	84
(b)	preamplifier board circuit diagram	85
fig 11(a)	power supply board component layout	86
(b)	power supply board circuit diagram	87
fig 12(a)	signal channel board component layout	88
(b)	signal channel board circuit diagram	89 (fold-out)
fig 13(a)	reference/demodulator board component layout	90 (fold-out)
(b)	reference demodulator board circuit diagram	91 (fold-out)
fig 14(a)	correlation board (C & SC versions) component layout	92 (fold-out)
(b)	sinetrac board (SC versions) component layout	92 (fold-out)
(c)	correlation and sinetrac circuit diagram	93 (fold-out)
fig 15(a)	dpm display board (D versions) component layout	94 (fold-out)
(b)	adc board (D versions) component layout	94 (fold-out)
(c)	digital models, circuit diagram	95 (fold-out)
fig 16(a)	demodulator monitor (mod 14) component layout	96 (fold-out)
(b)	demodulator monitor (mod 14) circuit diagram	

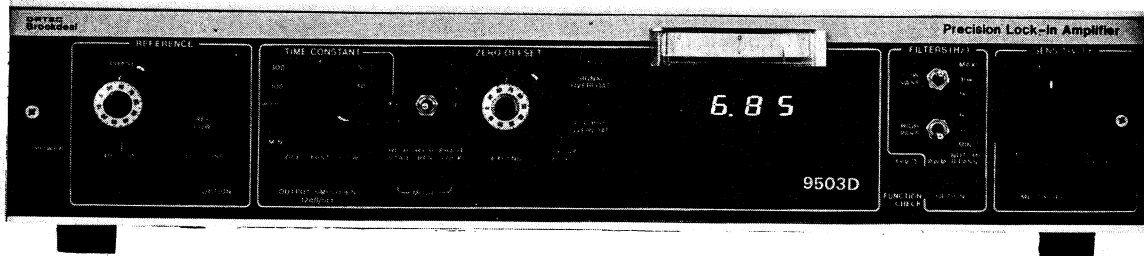
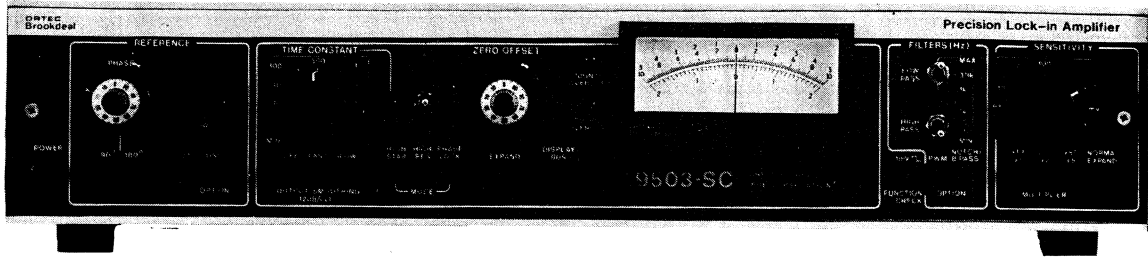

## 1 introduction

The 9503 series is a family of Precision Lock-in Amplifiers which incorporate circuitry and system innovations which advance the state of the art and enable low level ac signals to be accurately measured - even in extremely noisy environments.

Six models are available. These differ in the response modes available and the digital output facility. There are three basic versions; the standard 9503 with the normal (squarewave) response mode, the 9503C, which adds the analogue correlation mode and the 9503SC, which in addition to these two modes includes Sinetrac (fundamental only) mode and digital correlation mode. The SC version also has the signal gating facility. Each of these three versions is also available with a digital display and BCD output - these models carrying the suffix 'D'.

Both the Sinetrac and analogue correlation modes are based on new pulse carrier modulation techniques\*. These facilities either match the instrument response to the signal energy frequencies, even for complex waveforms, or suppress all harmonics to give a "fundamental only" response. When harmonic suppression is wanted, or when operating at low frequencies ( $\leq 1$ kHz), these options will greatly extend conventional lock-in performance with convenient operation. Further details on all of these response modes are given in the detailed operating instructions in section 5.4 and in greater detail in various Technical Notes available on request.

All the 9503 versions have excellent dynamic reserve and output stability - optimised by mode switching pushbuttons - so that it is very suitable for applications when the signal recovery power of a system has to be stretched to the very limit as well as for those applications where the measurement demands extreme precision.

When the frequency range of operation has to be extended, the extra bandwidth options make such measurements possible - wide band and without range or circuit card changes. All the necessary interface requirements are incorporated to build up the system capability by means of the range of slot-in modules. These can be fitted as specific applications requirements develop.

\*Patents applied for

2 specification

2.1 response modes model

	9503 and 9503D	9503C 9503D-C	9503SC 9503D-SC
normal (squarewave) mode	yes	yes	yes
analogue correlation mode	not available	yes	yes
sinetrac (fundamental only) mode	not available	not available	yes
digital correlation mode	not available	not available	yes

2.2 frequency range

normal & digital correlation mode 2Hz to 100kHz  
 sinetrac & analogue correlation modes 2Hz to 25kHz  
 lf option, mod 10 (all modes) 0.2Hz min  
 hf option, mod 11 (normal & digital correlation modes only) 200kHz max

2.3 signal channel (for preamplifiers see 2.9)

2.3.1 input impedance:

9503 (all versions) 100M $\Omega$ // 30pF differential or single-ended  
 9503/5001 100M $\Omega$ // 30pF differential or single-ended  
 9503/5002 see 2.9  
 9503/5003 100M $\Omega$ // 15pF unsymmetrical differential  
 9503/5004 5M $\Omega$ // 50pF unsymmetrical differential  
 9503/5006 100M $\Omega$ // 30pF differential or single-ended

2.3.2 SENSITIVITY (for fullscale output)

Expand	x1	x10
9503 (all versions)	10 $\mu$ V - 500mV	1 $\mu$ V - 50mV
9503/5001	100nV - 5mV	10nV - 500 $\mu$ V
9503/5002	100fA - 500nA	10fA - 50nA
9503/5003 or '4 or '6	10nV - 500 $\mu$ V	1nV - 50 $\mu$ V
9503 + 9433	10nV - 500 $\mu$ V	1nV - 50 $\mu$ V
9503/5003/5004	10pV - 500nV	1pV - 50nV

gain stability 0.02%/K  
 calibration accuracy  $\pm$ 3%

2.3.3 noise (shorted input)

8nV rms/ $\sqrt{\text{Hz}}$  typical  
referred to input

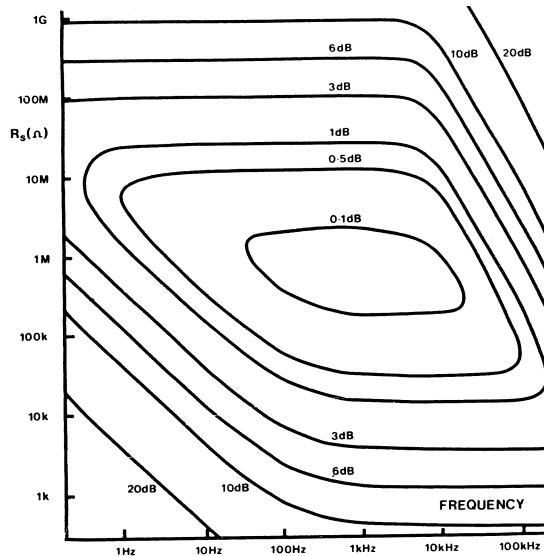

2.3.4 common mode rejection level

120dB typical  
3V p-p max

2.3.5 maximum non-coherent input voltage (for fullscale output)

using filters

700,000x fullscale  
or 2V p-p

broadband

3000x fullscale or  
2V p-p

2.3.6 FILTERS (standard)

HIGH PASS

MIN, 30Hz, 1kHz

LOW PASS

MAX, 30kHz, 1kHz

roll-off

6dB/octave

2.3.7 FILTERS - option 5011F

on/off control

rear panel slot-in

modes (switched)

by front panel pushbutton

frequency range

BANDPASS and NOTCH

frequency control

1Hz to 110kHz

- switched

5 position, decade steps

- continuous

coarse/fine drive

potentiometer with 15%  
range overlap

Q

~5 (may be changed  
internally)

BANDPASS mode

gain

unity

GAIN TRIM control



screwdriver adjust

NOTCH mode

rejection	>70dB typical
NOTCH DEPTH adjust	screwdriver adjust
option 5014 transient noise suppressor	rear panel slot-in
on/off control	by slide-switch on 5014 panel
signal bandwidth	10Hz to 500kHz in 1, 2, 5 steps
output monitor	monitors the processed signal at the psd input

2.4 Reference & Gate inputs

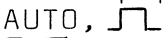
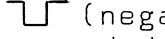
2.4.1 REFERENCE INPUT

impedance	for normal and SINETRAC (when applicable) modes
level	10M $\Omega$ // 30pF
MODE	140mV p-p to 200V p-p
	AUTO,  (positive pulse),  (negative pulse)
isolate facility	grounded or isolated (switch selected)
trigger mode	2-level arm and fire circuit triggering at mean level in AUTO mode, and 100mV above/below the mean level in  /  modes, respectively

2.4.2 analogue correlation INPUT

impedance	C and SC models only
level	10k $\Omega$
	1V rms calibrated, 2.5V pk max

2.4.3 gating INPUT

modes	SC models only
	SIGNAL GATING, DIGITAL CORRELATION (switched)
impedance	10k $\Omega$
level	TTL

2.5 Reference channel

2.5.1 PHASE shift

resolution	-5 $^{\circ}$ to 95 $^{\circ}$ continuous, 10-turn +90 $^{\circ}$ , +180 $^{\circ}$ pushbuttons <0.1 $^{\circ}$
------------	---

2.5.2 phase jitter (300ms time constant)

drift	0.005 $^{\circ}$ rms typical 0.03%/K
-------	---



- 2.5.3 phase accuracy (with 1V rms sinewave reference)
- continuous control  $\pm 1^\circ$
  - pushbutton controls  $\pm 0.2^\circ$
  - relative phase error between signal and reference inputs  $1^\circ$  (10Hz to 30kHz)
- 2.5.4 acquisition time 2s typical
- 2.5.5 frequency doubler by front panel 2f pushbutton
- 2.5.6 external phase control  $10^\circ/V$
- 2.5.7 internal oscillator (option rear panel) slot-in, 5012F)
- on/off control by front panel pushbutton
  - frequency control
    - switched 5 position, in decade steps
    - continuous coarse/fine drive potentiometer
  - total harmonic distortion 0.05% (2nd harmonic 0.005%)
  - amplitude 50mV rms to 5V rms
  - output impedance  $50\Omega$
  - output current 10mA pk max
  - frequency stability 0.1%/K typical

2.6 demodulator and output

- 2.6.1 modes (switched) HIGH STAB, HIGH RES, PHASE LOCK

- 2.6.2 dynamic reserve (demodulator overload capability) (subtract 10dB for SINETRAC and ANALOGUE CORRELATION modes)

MODE	OUTPUT EXPAND	
	x1	x10
Hi-stab	30dB	50dB
Hi-res	50dB	70dB

- 2.6.3 output zero stability (ppm/K)

Hi-stab	<10	<100
Hi-res	<100	<1000

- 2.6.4 ZERO OFFSET

both	$\pm 1 \times \text{fsd}$	$\pm 10 \times \text{fsd}$
------	---------------------------	----------------------------

2.6.5	TIME CONSTANT	
	HIGH STAB mode	MIN (20 $\mu$ s) to 10s
	HIGH RES mode	MIN (200 $\mu$ s) to 100s
	roll-off	6dB/octave
	mod 13, option	12dB/octave
2.6.6	OUTPUT SMOOTHING	
	time constant	slow: 1s
		fast: 0.1s
	roll-off	12dB/octave
		(adds to TC roll-off)
2.6.7	OUTPUT	$\pm 10V$ max, 10k $\Omega$
2.6.8	DIGITAL OUTPUT	D versions only
	format	parallel BCD 3 $\frac{1}{2}$ digit and sign, TTL compatible from 25 way Cannon socket. In addition, two control lines are provided for parallel printer interfacing.
	INPUT FILTER (switched on/off)	100ms at 12dB/octave roll-off
	SAMPLE PERIOD	MIN, NORMAL and SLOW modes, switched
	MIN	20 samples/s
	NORMAL (variable)	down to $\sim 1$ sample/s
	SLOW (variable)	down to $\sim 1$ sample/10s
2.6.9	meter (non D-versions)	centre zero, 76mm (3") scale
	accuracy	$\pm 2\%$ of fullscale
2.6.10	meters (D versions only)	
	analogue	edge meter, centre zero, 50mm (2") scale
	accuracy	$\pm 2\%$ of fullscale
	digital	3 $\frac{1}{2}$ digit and sign
	accuracy	$\pm \frac{1}{2}$ lsb
	digital error	$\pm 1$ lsb
2.7	<u>general</u>	
2.7.1	auxiliary slot-in DISPLAY BUS	output of suitable slot-ins may be monitored on the meter
2.7.2	FUNCTION CHECK	operation by front panel pushbutton when suitable reference is connected or internal oscillator is selected (when fitted)

	signal level	1mV rms squarewave
2.7.3	system status indicators	led indicators to show SIGNAL OVERLOAD, OUTPUT OVERLOAD, REF LOW, time constant x0.1
2.7.4	monitors	
	SIGNAL MONITOR	signal channel at input to the demodulator
	REFERENCE MONITOR	reference channel at input to the demodulator
	MONITOR (C & SC versions only)	waveform at input to the carrier pulse mixer
	demodulator (mod 14 option)	
	output level	5mV pk (70dB dynamic reserve) 50mV pk(50dB dynamic reserve) 500mVpk(30dB dynamic reserve)
	impedance	1k $\Omega$
	time constant	1 $\mu$ s
2.7.5	auxiliary power output	$\pm$ 15V, 50mA
2.7.6	POWER requirements	line only
	voltage ranges	95V to 130V } 190V to 260V } switched
	frequency	50-60Hz
	power, 9503	7W
	9503D	12W
	9503SC	10W
	9503D-SC	15W
2.7.7	dimensions	
	height	89mm (3 $\frac{1}{2}$ " )
	width	450mm (17 $\frac{3}{4}$ " )
	depth	483mm (19" )
	weight	6kg (131b)
2.8	<u>output options</u>	
2.8.1	omniphase 5042 (for use with two off 9503)	provides vector magnitude and phase outputs. Either may be monitored on 9503 bus network
2.8.2	ratiometer 5047	
	output functions	A-B/ C
	input ranges	A = +10V to -10V B = +10V to -10V  C  = 50mV to 10V
	function limits	
	A-B	<10V
	A/C	$\leq$ 1
	source impedances	<10k

2.8.3 noise measurement unit 5049 measures noise voltages in the frequency range 10Hz to 200kHz in bandwidths from  $\frac{1}{8}$ Hz to 250Hz

sensitivity 10x sensitivity setting of the 9503

frequency range 10Hz to 200kHz (with mod 11 version)

measurement bandwidth defined by time constant setting on the lock-in amplifier

output +10V maximum from 10k $\Omega$

bus output enables output voltage to be displayed on lock-in meter when DISPLAY BUS is selected

2.9 preamplifier options

2.9.1 voltage

	5001	5003	5004	5006
noise (s/c input)	7nV/ $\sqrt{\text{Hz}}$	2nV/ $\sqrt{\text{Hz}}$	800pV/ $\sqrt{\text{Hz}}$	4nV/ $\sqrt{\text{Hz}}$
noise matching range input	3k $\Omega$ -100M $\Omega$ differential	250 $\Omega$ -100M $\Omega$ unsymmetrical differential	40 $\Omega$ -5M $\Omega$ unsymmetrical differential	1k $\Omega$ -100M $\Omega$ differential
input impedance	100M $\Omega$	100M $\Omega$	5M $\Omega$	100M $\Omega$
CMRR	120dB	80dB	80dB	120dB

2.9.2 current : 5002

	$10^{-8}$ A/V	$10^{-7}$ A/V	$10^{-6}$ A/V
sensitivity	$10^{-14}$ A	$10^{-13}$ A	$10^{-12}$ A
max dc i/p current	100nA	10 $\mu$ A	1mA
input impedance	10k $\Omega$ , 100mH	100 $\Omega$ ; 3mH	1 $\Omega$ , 15 $\mu$ H
frequency range	0.5Hz-10kHz	0.5Hz-200kHz	0.5Hz-200kHz

5005

sensitivity  $10^{-9}$  A/V to  $10^{-4}$  A/V in decade steps

frequency dc to 1kHz

input current 0 to 10nA, 0 to 100nA

offset off, switched + and -

Unless otherwise stated, specifications refer to 1kHz and 20 $^{\circ}$ C.

- iv) Use the continuous PHASE control, and if necessary the 90° pushbutton to null the output.
- v) Change phase by 90° to give maximum output.
- vi) If necessary, select the required output polarity by means of the 180° pushbutton.
- b) If necessary, reset SENSITIVITY and possibly the EXPAND settings.
- c) It may now be necessary to remove the O/P SMOOTHING (if selected in (i) above) in certain applications, eg servo systems.
- d) If the system overloads at any of the three points (pre-filter, psd input and psd output) sensed by the OVERLOAD indicator circuits, it can be restored to normal operation by suitable adjustment of the output TIME CONSTANT, ZERO OFFSET or SENSITIVITY/EXPAND controls (see section 5.6.4 page 45).
- e) ZERO offset may be adjusted by selecting + or - on the toggle switch and selecting the required offset by means of the ten-turn duo-dial control.

#### FUNCTION CHECK

Correct operation of the 9503 may be verified by depressing the FUNCTION CHECK pushbutton after connection of a suitable reference (see section 3.2.1, 1 and 2 above). Set SENSITIVITY control to 1mV, depress the EXPAND pushbutton and follow procedures from paragraph 3 onwards and verify correct operation of all controls. When correctly phased with no OFFSET applied, a positive fullscale output should be obtained.

#### output specification

- 1) The OUTPUT connector provides a fullscale output of ±10V dc from a resistance of 10kΩ.
- 2) The SIGNAL MONITOR socket (rear panel) enables the signal input to the phase sensitive detector (demodulator) to be monitored.
- 3) The REFERENCE MONITOR socket (rear panel) enables the reference input to the phase sensitivity detector (demodulator) to be monitored.

3 basic operation instructions (see section 5, page 21  
for detailed operating  
instructions)



3.1 switching on

3.1.1 check that the 9503 is set for operation at the required line voltage and that the correct fuse is fitted.

3.1.2 connect the instrument to the line supply and pull the POWER button.

3.2 setting the controls

3.2.1 Normal (squarewave) operation - applicable to all models

- 1) Connect the reference voltage and the signal voltage.
- 2) Set REFERENCE INPUT MODE to AUTO unless the reference waveform is a pulse when  or  should be selected, as appropriate.
- 3) Check that the REF LOW light is extinguished.
- 4) For 2nd harmonic measurements, depress the 2f pushbutton.
- 5) Select LOW PASS and HIGH PASS FILTERS as required.
- 6) Select HIGH STAB or HIGH RES mode as required.
- 7) Ensure that the pushbuttons OSC, PHASE LOCK, DISPLAY BUS, FUNCTION CHECK, PWM and NOTCH/B'PASS are not depressed. In SC models select NORMAL position on the 3-position rear panel slide switch.
- 8) To set the phase:
  - a) i) Select SLOW or FAST OUTPUT SMOOTHING settings if there is low frequency chop or beats from the output.
  - ii) Select a suitable TIME CONSTANT (for setting up, typically 1 second).
  - iii) Adjust the SENSITIVITY to obtain an on-scale indication on the meter without OUTPUT OVERLOAD indication).

3.3 operation in other response modes - applicable to  
C and SC models

The 9503C has facilities for normal (squarewave) lock-in amplifier response and analogue correlation response. The 9503SC models have, in addition to these modes, Sinetrac (fundamental only) response and digital correlation response. The SC model also includes the signal gating facility. Of these 4 response modes, the Sinetrac and analogue correlation responses are related to the Pulse Carrier Modulation mode of operation (selected by the front panel PWM pushbutton).

The digital correlation facility does not use the Pulse Carrier Modulation technique.

The signal gating facility may be used with any of the normal, sinetrac and analogue correlation modes of operation.

Both the C and SC models are fitted with an "SC" section of rear panel which carries inputs, monitor output and selector switches.

3.3.1 Sinetrac mode

To select SINETRAC mode:

front panel:	depress the PWM pushbutton
rear panel (SC section):	select NORMAL and SINETRAC settings on the two slide switches

The reference voltage may be of any form and is applied to the REFERENCE INPUT of the 9503SC, as described in the normal mode above. The instrument now has a SINETRAC (fundamental only) response and may be used with signal and reference frequencies in the range 2Hz to 25kHz (0.2Hz to 25kHz in the mod 10 version). All front panel facilities, including the precision phase-shifter, are available, as in the normal lock-in.

In this mode the MONITOR output on the SC panel carries a 100mV rms sinewave phase-shifted by the 9503SC reference circuits relative to the original reference input. The 2f NULL control is applicable to the SINETRAC mode, its purpose being to reduce the second harmonic response of the system to an acceptable level. It is factory-set to give optimum performance across the frequency range of the instrument and should require no further adjustment. Should the need arise, however, for example, to minimise second harmonic

response in a particular frequency regime, the procedure for setting up is described in the Facilities and Detailed Operating Instructions, section 5 on page 21.

### 3.3.2 Analogue correlation mode

To select ANALOGUE CORRELATION mode:

front panel: depress the PWM pushbutton  
rear panel (SC section): select NORMAL and ANALOGUE CORRELATION settings on the two slide switches.

The REFERENCE INPUT socket to the 9503SC should not be used in ANALOGUE CORRELATION, instead the "any waveform" reference should be applied to the INPUT socket of the SC panel section. In this mode the SC MONITOR output is a scaled version of the applied reference waveform (at a level of -20dB).

Note that, as in SINETRAC, the frequency content of the signal and ANALOGUE CORRELATION reference should be limited to the range 2Hz to 25kHz (or 0.2Hz to 25kHz in the mod 10 version). If the reference has the form of a digital signal, then the high harmonic content can be accommodated in the DIGITAL CORRELATION mode described in section 3.3.3 below.

The controls in the reference section of the front panel are disabled when ANALOGUE CORRELATION is selected and the front panel SENSITIVITY controls are calibrated when the ANALOGUE CORRELATION reference is set to 1V rms. A procedure for calibration is described in section 5.4.3 on page 37. Note also that in this mode variations in amplitude of the reference voltage will of course reflect in the output level.

### 3.3.3 Digital correlation mode

To select DIGITAL CORRELATION mode:

front panel: do not depress the PWM pushbutton  
rear panel (SC section): select DIGITAL CORRELATION setting on the lower of the two slide switches; setting of the upper switch is unimportant.

DIGITAL CORRELATION gives optimum signal recovery when the signal has the form of a digital pulse train (minimum pulse width is 10 $\mu$ s).



The digital reference signal should be applied to the lower INPUT socket with a minimum pulse amplitude of 2V for effective triggering. As the 9503SC reference channel is disabled in this mode of operation, the front panel phase-shift controls are inoperative. The SENSITIVITY calibration remains valid in DIGITAL CORRELATION except that proper allowance should be made for the structure of the digital waveform.

#### 3.3.4 The signal gating facility

This is a comprehensive mode of operation in which the signal input to the demodulator can be blocked by the application of a "high" level (2V minimum) to the SC gating input. SIGNAL GATING is effective either in normal lock-in operation or when a pulse carrier modulation mode is selected. The 9503SC should be set as follows.

front panel:	select PWM if required
rear panel (SC section):	select SINETRAC or ANALOGUE CORRELATION as required and SIGNAL GATING on the two slide switches

The gating signal should be applied to the lower INPUT socket on the SC panel and will normally be at the second harmonic of the reference fundamental. In this way, information is gated from each half cycle of the signal waveform and no undesirable offsets are introduced in the output from the lock-in system.

#### 3.4 Preamplifiers

The preamplifiers (models 5001 to 5006) are normally supplied separately from the 9503 and may be fitted into the rear panel of the instrument or used remotely.

Fitting instructions

- a) Remove the rear panel blanking plate if the preamplifier is to be mounted in the mainframe.
- b) Fit the preamplifier into the rear panel and tighten the securing screw.
- c) Connect the power cable from the preamplifier to the mainframe and with the BNC cable supplied connect the OUTPUT of the preamplifier to the signal INPUT A of the 9503.

NB: If the preamplifier is to be used remotely, longer power and signal cables can be supplied to order (remote adaptor kit 5029).

#### VOLTAGE PREAMPLIFIERS

Select single-ended or differential signal input as required. Connect the signal voltage(s). Continue operating instructions as described in section 3.2.1.

#### 5002 CURRENT PREAMPLIFIER

Connect the signal current to the INPUT of the preamplifier. Select the SENSITIVITY required on the panel of the 5002. This control allows a trade-off to be made between the sensitivity and maximum dc input current allowable (see scales on 5002 panel). Continue operating instructions as described in section 3.2.1.

## 4 system description

### 4.1 normal (squarewave) mode - applicable to all models

#### 4.1.1 introduction

The basic 9503 is a broadband lock-in amplifier incorporating a variable gain ac amplifier, a reference section with phase-shifting facilities, a precision demodulator and output dc amplification and filtering. A simplified block diagram of the system is shown in figure 1.

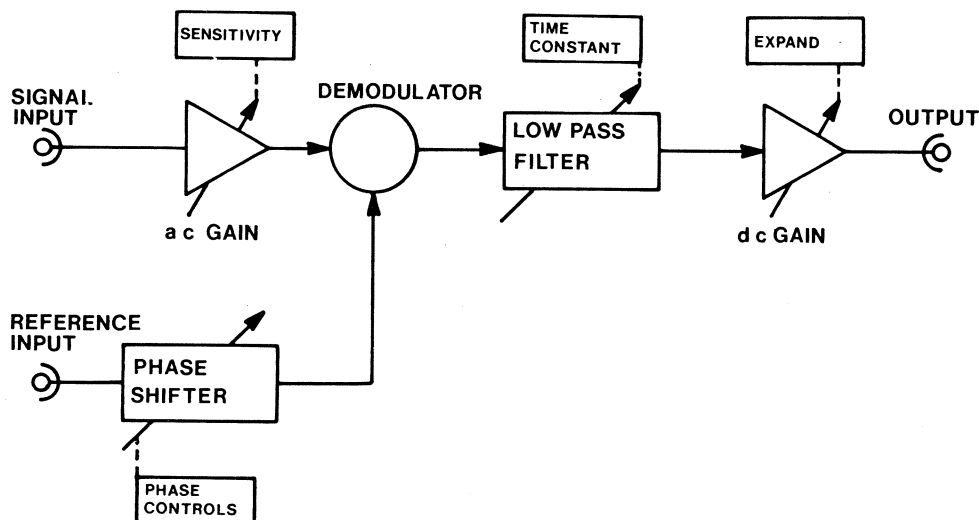

figure 1

#### 4.1.2 ac amplifier

The functions of the ac amplifier are:

- i) to provide gain or attenuation of the signal of interest so as to provide a signal input of the correct level to the phase demodulator. The gain/attenuation is controlled by the SENSITIVITY switch
- ii) to provide switchable HIGH-PASS and LO-PASS filters in order to reduce noise not near to the signal of interest
- iii) to provide means for inserting signal-conditioning slot-in modules or options, such as tunable filters and transient-noise suppression filters

- iv) to provide means of injecting a FUNCTION CHECK signal derived from the reference channel
- v) to provide a high impedance true differential interface at the signal input.

#### 4.1.3 the reference channel

The purpose of the reference channel is to generate a symmetrical squarewave to drive the reference input of the demodulator. This waveform is either of the same frequency as the reference trigger input or twice that frequency if required, and is movable in phase by accurate amounts from the front panel PHASE control or from the EXT PHASE control input socket.

The reference channel consists of:

- i) a trigger circuit with switchable threshold levels for accurate, jitter-free triggering from sinewaves, triangles, ramps, squarewaves and negative or positive pulses
- ii) an isolation switch to allow the reference input to be floated with respect to signal ground
- iii) a frequency doubler
- iv) a precision phase-shifter, controlled either from the front panel phase control or voltage-controlled from a rear panel input socket
- v) provision for triggering from an optional slot-in oscillator.

#### 4.1.4 the demodulator

The demodulator may be thought of as a linear gating circuit which is controlled by the reference input waveform.

An important feature of this circuit is its ability to handle noise signals several million times greater than any error signals which may be generated by the gating action or by the subsequent dc amplification circuits. Thus, in-phase signals (which are coherent with the reference gating waveform and give dc outputs from the demodulator) may be many orders of magnitude below the noise level without the offset errors becoming significant.

The output from the demodulator is switched into a low-pass filter section which provides the primary noise attenuation, the effect being variable by the TIME CONSTANT control. The manually adjustable ZERO OFFSET control is also applied to the filter

and the output is taken to the OUTPUT EXPAND amplifier which provides a gain of x1 or x10, as selected. An OUTPUT SMOOTHING filter provides additional smoothing at 12dB/octave with the rise-time switched from the front panel.

#### 4.1.5 MODES of operation

The use of the MODE switch on the 9503 changes the distribution of ac gain and dc gain within the lock-in so as to optimise the performance of the system under different operating conditions. As the overall sensitivity of the lock-in is established by the product of ac gain and dc gain, care is taken to preserve this product when mode switching so that the sensitivity of the system remains unchanged. In HI-STAB MODE, therefore, the dc gain of the demodulator is switched to its lowest value and compensated by additional ac gain in the signal channel. In this connection, the output (dc) stability is at a maximum, making the instrument ideal for the precision measurement of ac signals. In HI-RES MODE, the demodulator gain is switched to its maximum value, resulting in a deterioration in dc output stability. The ac signal gain is reduced by a corresponding amount so as to make maximum use of the overload capability of the demodulator. This mode of operation, therefore, is aimed at extracting signals from an extremely noisy background, a situation where the reduced output stability is not normally significant.

The 9503 also provides a PHASE-LOCK facility which may be used with either HI-STAB or HI-RES modes of operation. With PHASE-LOCK selected by the front panel pushbutton, the response of the demodulator is modified to make the instrument suitable for locking the phase of a voltage-controlled oscillator to the phase of an incoming signal.

#### 4.2 sinetrac and correlation modes (C and SC models only)

##### 4.2.1 introduction

The circuitry for SINETRAC and CORRELATION operation is contained on two printed circuit boards mounted in the centre of the unit.

The first printed circuit board contains all the pulse carrier modulation and gating circuitry and is the centre horizontally mounted board. The second board contains the sinewave generation circuits required for the SINETRAC mode of operation and is a plug-in board mounted vertically.

## 4.2.2 principles of operation

### (a) pulse carrier modulation modes

A simplified block diagram of the 9503SC system is shown in figure 2.

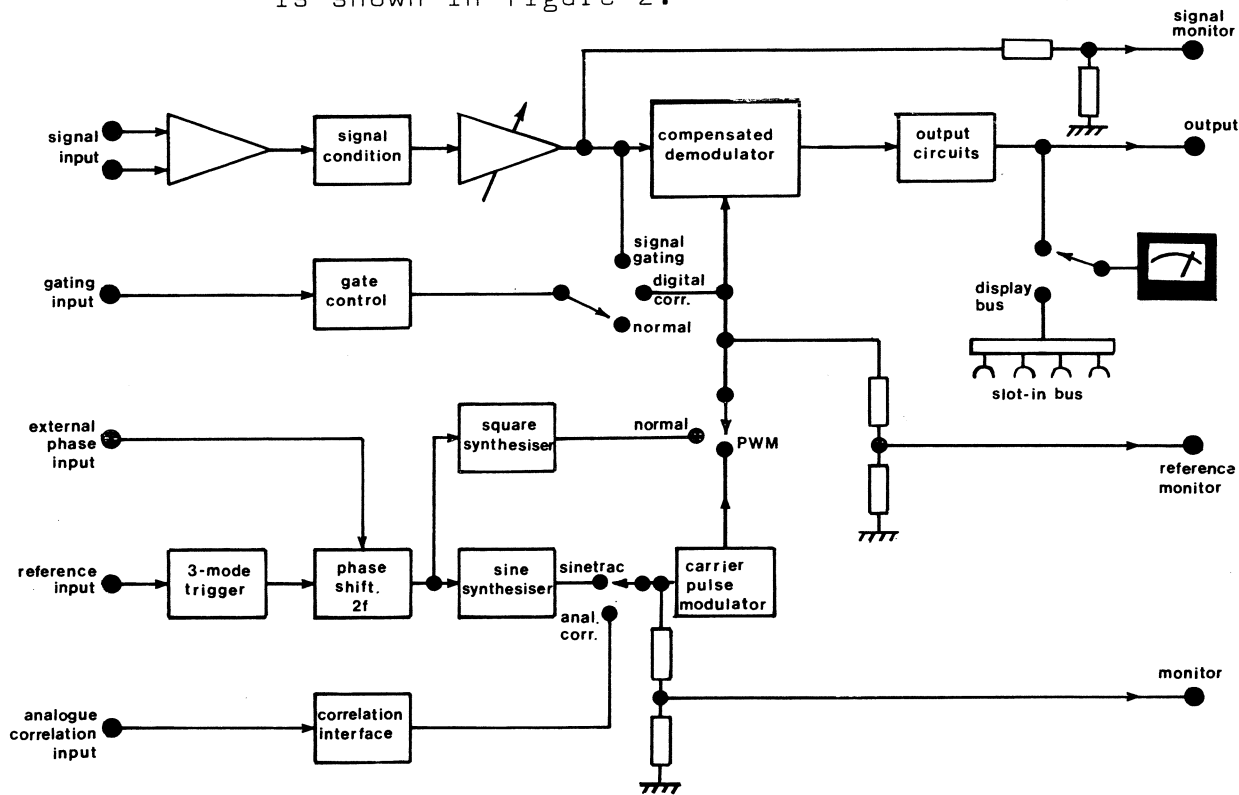

figure 2

In the pulse carrier modulation modes of operation (ANALOGUE CORRELATION and SINETRAC), the anti-phase squarewave reference voltages which are applied to the demodulator for "normal" operation are switched out and replaced with driving voltages from the pulse carrier modulator. These new driving waveforms are at a relatively high, fixed, frequency (100kHz).

#### i) analogue correlation response mode

The effect of applying an ANALOGUE CORRELATION waveform to the input of the pulse carrier modulator is to modulate the mark/space ratio of the output waveform so as to give a train of pulses (at the fundamental 100kHz) whose width varies in proportion to the instantaneous value of the applied waveform. The effective depth of modulation depends upon the amplitude of the applied waveform which should be adjusted to 1V rms for calibrated operation. A procedure for doing this is included in the detailed operating instructions.

The effect of the pulse carrier modulator output on the demodulator is to impose a system response governed by the harmonic content of the modulating waveform, hence in ANALOGUE CORRELATION mode the system may have an "any waveform" response, whilst in SINETRAC mode the modulating waveform is arranged to be sinusoidal, resulting in a "fundamental only" response.

ii) sinetrac response mode

In SINETRAC mode of operation, the reference waveform may be of any form and is applied to the REF INPUT of the 9503 in the usual way (see section 5.5.1 page 38). This waveform is subsequently converted to a precision squarewave in the 9503 which can be phase-shifted by the front panel PHASE controls.

On selecting SINETRAC operation, the phase-shifted squarewave is connected to the sinewave converter, a piecewise-linear network giving a sinewave of low harmonic content at a fixed amplitude and locked in phase to its squarewave input. The sinewave is adjusted to 1V rms and applied to the modulation input of the pulse carrier modulator.

iii) gain compensation

The use of a pulse carrier modulation waveform for the demodulator reference input results in a loss of dc gain in the demodulator. This is compensated by adding an extra gain section of 10dB in the signal channel. The additional amplifier is located on the centre (horizontal) printed circuit board and provides the signal input to the demodulator. Note that the redistribution of gain results in a reduction of 10dB in the dynamic reserve of the system.

b) GATING modes

DIGITAL CORRELATION mode is included with the SIGNAL GATING facility in this section, although the implementation is quite different in the two cases.

i) signal gating

The gating in the signal channel is carried out at the input of the additional amplifier described in section a(iii) above. This amplifier is permanently in circuit in the C and SC models, with its gain switched from unity to 10dB when a pulse

carrier modulation mode is selected. SIGNAL GATING is available in normal, sinetrac and analogue correlation modes.

ii) digital correlation

On selecting DIGITAL CORRELATION, the input pulse train is standardised in amplitude and used to generate a pair of anti-phase driving waveforms. These are applied directly to the demodulator reference terminals in place of the reference drive from the reference channel or pulse carrier modulator.



## 5 facilities and detailed operating instructions

### facilities

### operating instructions

#### 5.1 power

The 9503 models operate from ac supplies of 95V to 130V or 190V to 260V ac, 50/60Hz.

The line cord must be connected as follows:

#### European colour coding

connect to live - brown  
connect to neutral - blue  
connect to ground - green/yellow

#### CSA colour coding

connect to live - black  
connect to neutral - white  
connect to ground - green

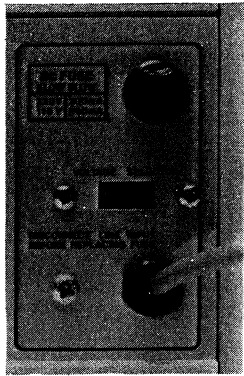

Check whether the line supply is 115V or 230V and that the instrument is set to the correct voltage. The line voltage range is set by the VOLTAGE SELECTOR switch on the rear panel.

Check that the correct FUSE is fitted. The fuse is 32 x 6mm (1 $\frac{1}{4}$ " x  $\frac{1}{4}$ ") slow-blow type and the correct ratings are:

230V	200mA
115V	400mA



Connect the instrument to the line supply and pull the POWER button on.

#### 5.2 checks using the FUNCTION CHECK facility

The system FUNCTION CHECK facility serves the dual purpose of permitting a functional check of the system and also of being useful as a convenient way of enabling the user to become familiar with the effects of each control.

Set the front panel controls and pushbuttons for simplest operation as follows:

facilities

operating instructions

NB It is not designed as a frequency independent calibration source (see Section 5.12.2 page 54)





<u>control</u>	<u>setting</u>
FILTER, HIGH PASS	MIN
FILTER, LOW PASS	MAX
SENSITIVITY	1mV
sensitivity	
MULTIPLIER	x1
OUTPUT SMOOTHING	OFF
MODE	HIGH RESERVE
TIME CONSTANT	300ms
ZERO OFFSET	OFF
continuous PHASE	
control	0.0
OSC, 2f, PWM,	
NOTCH/B'PASS	
buttons	unpressed
90°, 180° PHASE	
buttons	unpressed
DISPLAY BUS	unpressed
EXPAND	pressed
FUNCTION CHECK	see below

On the SC models only:

<u>control</u>	<u>setting</u>
rear panel	
(SC section)	
mode switch	SINETRAC
gating switch	NORMAL

Connect the reference voltage to the REFERENCE INPUT socket on the rear panel and select the appropriate trigger MODE.

sine, triangle	AUTO
+ve pulses, square	
or +ve slope	
+ve pulses, square	
or -ve slope	

Check that REF LOW led is extinguished and press the FUNCTION CHECK button.

The 9503 is operating correctly if the meter indicates positive fullscale. Near the extreme of the 9503's frequency range, due to phase shifts in the FUNCTION CHECK signal at these frequencies, it may be necessary

facilities

operating instructions

On SC models it is possible to check SINETRAC mode (provided the reference voltage is at a frequency  $\leq 25\text{kHz}$ ).

to use some phase adjustment to give maximum indication on the meter.

After the above check is completed, change the following control setting:

PWM button                      pressed

The meter should now indicate 0.81 fullscale (positive). This change in reading is because the lock-in is now operating in SINETRAC mode and therefore measuring only the fundamental component of the 1mV rms squarewave.

5.2.1 detailed checks of the control functions using the FUNCTION CHECK facility

NB The FUNCTION CHECK signal is a squarewave of 2mV p-p (1mV rms).

a) SENSITIVITY and EXPAND

1mV fsd may be selected in two different ways:

SENSITIVITY	EXPAND
100 $\mu$ V	unpressed
1mV	pressed

Check that both combinations give fullscale on the meter. Press the 90° PHASE button and check that the meter now indicates zero for each of the above settings.

b) TIME CONSTANTS and OUTPUT SMOOTHING

Note that the risetime (10% to 90%) is  $\sim 2.2 \times$  the TIME CONSTANT setting.

A rough evaluation of the effectiveness of the TIME CONSTANT and OUTPUT SMOOTHING controls may be made by observing the meter response to abrupt changes in output signal level caused by switching PHASE by 90°. Below settings of 100ms the meter response dominates the TIME CONSTANT. Thus a storage oscilloscope

facilities

operating instructions

connected to the OUTPUT socket is needed to evaluate properly the 30ms, 10ms, 1ms and MIN settings.

Reset the MODE switch to HIGH STAB. Check that the green x0.1 led lights. Repeat the above measurements. The TIME CONSTANTS should all be reduced by a factor of 10.

c) ZERO OFFSET

The ZERO OFFSET control provides up to 10x fullscale deflection of either polarity, as selected by the +/-OFF/- switch.

Up to ±10x zero offset control may be simply checked out by using a combination of the SENSITIVITY and EXPAND controls:

SENS - MULTIPLIER		EXPAND	ZERO OFFSET switch	variable	meter	
1mV	x1	pressed	OFF	0.0	+fsd	
			-	1.0	centre 0	
			-	2.0	-fsd	
100µV	x5	pressed	-	3.0	-fsd	
			pressed	-	4.0	+fsd
				-	5.0	centre 0
100µV	x2	pressed	-	6.0	-fsd	
			pressed	-	9.0	+fsd
				-	10.0	centre 0

To check positive ZERO OFFSET settings, press 180° PHASE button and repeat the above measurements.

NB Polarities in the ZERO OFFSET and meter columns are opposite.

d) variable PHASE control

The PHASE controls (continuous and pushbutton) can be conveniently checked by using the 1mV FUNCTION CHECK facility.

Set the 9503 controls as described on page 22. Press the FUNCTION CHECK button. The meter should indicate positive fullscale.

As the continuous PHASE control is turned clockwise, the meter deflection should decrease

facilities

operating instructions

until it reaches zero (when the variable PHASE dial should indicate  $90^{\circ}$ ). Press the  $90^{\circ}$  pushbutton - the meter should now read negative fullscale. Press the  $180^{\circ}$  pushbutton - the meter should now read positive fullscale.

### 5.3 signal channel

The signal channel operates over a frequency range 2Hz to 100kHz and will accept in-phase signals up to 500mV rms and noise voltages up to 2V p-p (at the SIGNAL INPUT socket on the 9503). Maximum fullscale sensitivity of the standard input of the 9503 is  $1\mu\text{V}$  rms and the resolution is better than  $1\text{nV}$  rms.

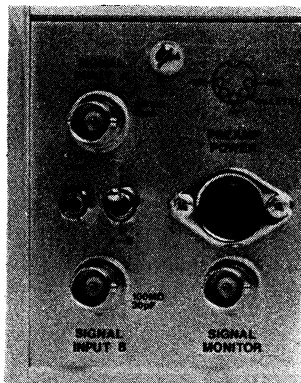

For the majority of applications the signal source may be connected directly to the 9503 INPUTS by means of coax cables and BNC connector. The impedance of either is not critical at those frequencies at which the 9503 is operated. The most frequent sources of avoidable noise are poor screening of the signal source and connecting leads and ground loops caused by a difference in the 'ground' potentials of the signal source and the lock-in amplifier.

It may be necessary to make use of the floating or differential input in order to break a ground loop or measure the output of a floating source. In some cases added resolution or fullscale sensitivity greater than that provided by the 9503, will be required. In this case, one of the 5000 series preamplifiers (sometimes in conjunction with the 9433 transformer) will meet the requirements.

Preamplifier connection and installation is as follows:

Whatever preamplifier is selected, it may be mounted in the back of the 9503, its OUTPUT being connected to the SIGNAL INPUT A of the 9503 via a 230mm (9") BNC terminated, coax cable and its power supplied by a 230mm (9") 5-pin

facilities

operating instructions

DIN-connector terminated power cable connected to the 9503 power outlet. To mount a preamplifier in the 9503, remove the rear panel blanking plate nearest to the left-hand side, viewed from the rear. Insert the body of the preamplifier into the space left by the blanking plate, pushing the bottom edge of the preamplifier panel into the slot in the lower extrusion. Push the top edge of the panel against the top extrusion and tighten the fixing screw. The preamplifiers may also be mounted remotely next to the signal source if required: the 5029 extender cables can be supplied for this purpose from the factory.



#### 5002 current preamplifier

Current preamplifiers can be needed whenever the signal source is a current source as, for example, electron multipliers, ion collectors or photomultipliers. Although they are not always essential, current amplifiers minimise the effects of microphony and input cable capacitance at high frequencies and also remove the need to build carefully screened load resistor assemblies. In most cases the anode of an electron multiplier or photomultiplier can be connected directly to the input of the 5002 since its input is dc-coupled and is capable of sinking considerably more dc current than the ac current which it is measuring.

#### 5003 nanovolt preamplifier

This is a high impedance, very low noise amplifier which should be used to measure signals from sources with low self-generated noise and high

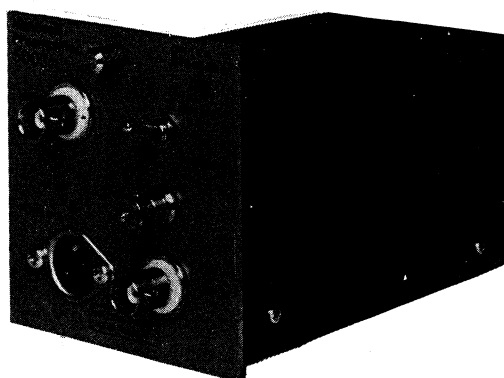
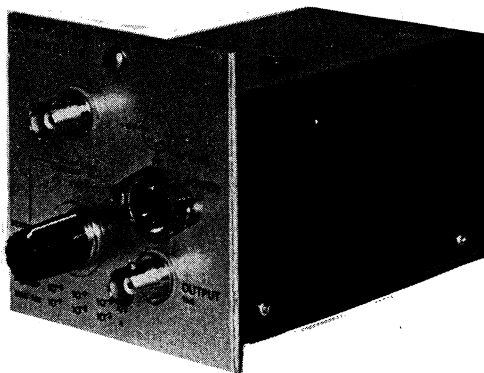

## facilities

impedance, such as capacitance microphones or high resistance cryogenic sources. Since it has an unsymmetric differential input it is very effective in breaking ground loops.

### 5004 ultra low-noise preamplifier

This is a medium impedance amplifier with such low noise that resolution of less than a nanovolt, even with relatively fast response times (~300ms), is possible. It is, of course, useful only when measuring from very low noise sources, such as resistance thermometers operating at cryogenic temperatures or cooled mercury cadmium telluride detectors. Its input is also unsymmetric differential.

### 5005 dc current preamplifier

This is a low frequency high sensitivity current-sensitive preamplifier. It is primarily for use in ratiometric experiments as a dc current amplifier between the photodetector used to monitor the excitation source before chopping, and the C input of the 5047 ratiometer.

### 5006 differential preamplifier

This is the most often used preamplifier since it has differential capability with excellent common-mode rejection across its frequency range. This enables it to be connected to 'grounded' sources in such a way as to break groundloops and also since it is truly differential it can be used to measure floating sources

## operating instructions

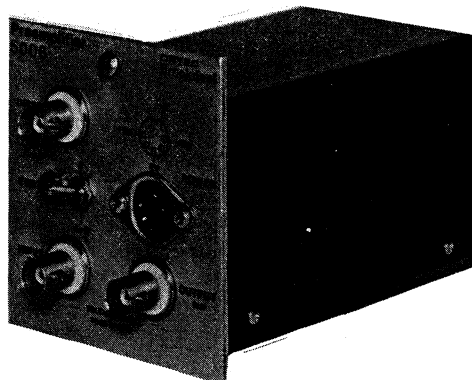
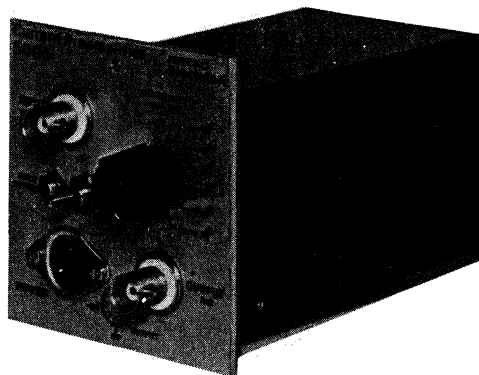
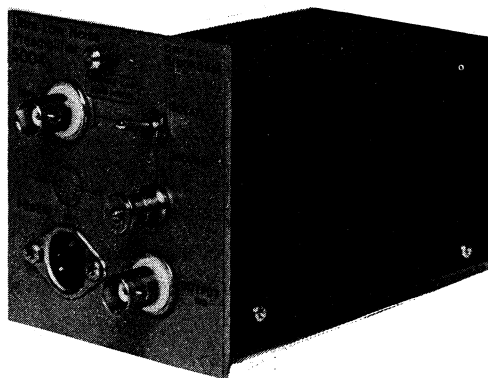

facilities

operating instructions

such as the outputs of ac bridges or Hall effect elements without placing an unsymmetric load on the source.

### 5.3.1 SENSITIVITY and EXPAND

SENSITIVITY is variable from 10 $\mu$ V to 500mV fullscale in 1, 2, 5 steps (when EXPAND is unpressed). The SENSITIVITY may be increased by a factor of x10 by means of the EXPAND button. A red warning led indicates overload in the signal channel.



Rotate the SENSITIVITY control until the meter shows at least one third fullscale. If the SIGNAL OVERLOAD indicator lights, select HI-RES mode. If the indicator remains on, then decrease the SENSITIVITY and proceed to obtain an on-scale reading by using the EXPAND pushbutton. If the input signal is less than 0.5 $\mu$ V then a preamplifier may be required.

If it is not possible to obtain adequate meter deflection (even with expand) due to the SIGNAL OVERLOAD light indicating noise overload in the signal channel, it may be necessary to use some filtering in the signal channel (see section 5.3.2).

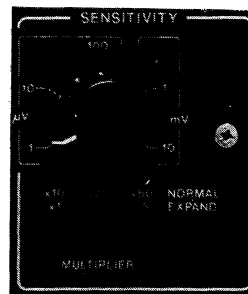

### 5.3.2 HIGH PASS & LOW PASS FILTERS

The HIGH PASS and LOW PASS FILTERS are active (6dB/octave roll-off) filters.

The HIGH PASS -3dB points are <2Hz (MIN), 30Hz and 1kHz.  
The LOW PASS -3dB points are

The criteria used for setting the HIGH PASS and LOW PASS FILTERS depends on the application:



facilities

>100kHz (MAX), 30<sup>k</sup>Hz and 1kHz.

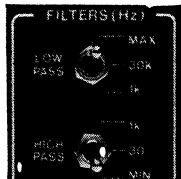

operating instructions

1) For applications where absolute amplitude is not important, it is normal (where possible) to set the FILTERS to frequencies not less than a factor of 3 and not more than 30, from the reference frequency, fr.

Examples:

fr	HIGH PASS	LOW PASS	gain loss	phase shift
10kHz and above	1kHz	MAX	~1%	~ 6°
(increase with fr)				
3kHz	1kHz	30kHz	7%	~16°
1kHz	30Hz	30kHz	<1%	< 1°
300Hz	30Hz	1kHz	~5%	~10°
100Hz	2Hz(MIN)	1kHz	<1%	~ 6°
30Hz	2Hz(MIN)	1kHz	<1%	~ 2°
and below ----- (increase with decreasing fr)				

As mentioned in the previous section, noise overload may prevent a sufficient meter deflection from being obtained. Under such circumstances it is quite permissible to bring the filter settings in closer than indicated above provided that the resulting gain loss and phase changes are not critical factors in the measurement.

2) For applications where absolute gain and phase accuracy are important, it is recommended that the HIGH PASS - MIN and LOW PASS - MAX settings be used.

facilities

operating instructions

### 5.3.3 option filter - 5011F active filter

The 5011F active filter has two distinct modes of operation, the BANDPASS mode and the NOTCH (band reject or band stop) mode. Since the 9503 has a very large dynamic range, it is unlikely that its ability to cope with random noise would be improved in any practical sense by the addition of a BANDPASS filter. However, overload by discrete frequency noise, such as line pick-up, is a real possibility and it is recommended that under such circumstances the 5011F be installed and operated in its NOTCH mode. The reason for choosing to operate the filter in the NOTCH mode and tuning it to the interference frequency rather than the BANDPASS mode and tuning it to the signal frequency, is that the rapid changes in phase-shift caused by such filters take place at their centre frequency and thus cause measurement errors when tuned to the signal frequency.

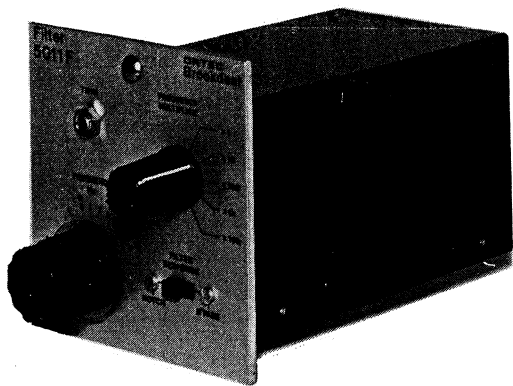

- 1) In order to reject an interference signal using the 5011F:
  - a) connect the SIGNAL MONITOR to an oscilloscope and observe the interference signal
  - b) press the front panel button labelled NOTCH/B'PASS
  - c) select the appropriate FREQUENCY RANGE and the NOTCH mode on the 5011F
  - d) turn the tuning dial until the interference signal is sharply attenuated
  - e) null the signal by adjusting the NOTCH DEPTH-TRIM screwdriver control and retuning as necessary. By careful adjustment a rejection factor in excess of 3000 is obtainable; for most applications a factor of 300 is sufficient and easy to set.

2) Another common use for the 5011F in its NOTCH mode is the rejection of the fundamental signal in second harmonic measurements. In this case it is not necessary to use an oscilloscope, the meter on the 9503 being an excellent indicator of the presence of the fundamental signal:

- a) set up the phase and sensitivity to measure the fundamental signal. That is, adjust them to give a reasonable on-scale indication on the meter. Press (or release) the 90° PHASE button to give zero indication on the meter. Do not press the 2f selector button yet.

facilities



operating instructions

- b) press the NOTCH/B'PASS selector button and tune the 5011F until the indication on the meter first moves in one direction and then swings through zero. As it goes through zero, the 5011F is correctly tuned. Press/release the 90° PHASE button. Any residual deflection of the meter can be nulled using the NOTCH DEPTH-TRIM.
- c) the 2f button can now be pressed to measure the second harmonic.

Installation of the 5011F  
(see page 52)

During the installation of any of the internally connected slot-ins, the 9503 should be switched off and disconnected from the line supply.

Remove from the rear panel any of the blanking plates. Remove the top cover. Inside the 9503 is a brown 10-way plug. Connect the brown 10-way socket on the flying lead of the 5011F into this plug; keyways in the plug and socket will prevent incorrect polarisation. Insert the body of the 5011F into the space left by the blanking panel, pushing the bottom edge of the 5011F control panel into the slot in the lower extrusion. Push the top edge of the panel against the top extrusion and tighten the captive fixing screw. Replace the top cover.

5.3.4 option - 5014  
transient noise  
suppressor

The 5014 transient noise suppressor is designed to reduce the effect of transient interference which may accompany the signal. This type of interference usually occurs randomly and can be very troublesome in certain

For installation and operating instructions of the 5014, see the handbook which accompanies the slot-in.

facilities

operating instructions

types of measurement because the lock-in takes a long time to recover from a transient overload when operating with a large TIME CONSTANT. It cannot usually be suppressed satisfactorily by the use of simple low pass filters in the signal channel.

The 5014 is inserted in the lock-in amplifier between the output of the signal channel and the input to the psd. At this point the coherent signal lies within well-defined limits for phase-sensitive detection and is transmitted linearly by the 5014. A control is provided to set the SIGNAL BANDWIDTH to a suitable value.

The effect of the 5014 is to define a very small bandwidth (the 'power' bandwidth) for large amplitude events. This bandwidth is approximately 50 times smaller than the selected signal bandwidth. The result is that the rate of rise and the final amplitude of transient events is drastically reduced before input to the psd.

#### 5.3.5 SIGNAL GATING - applicable to SC models only

Normally, lock-in amplifiers increase the level of the signal relative to interference, by sampling (or more precisely by rectifying) the repetitive signal at a consistent phase; and by relying upon non-coherent noise being rectified at random phase. Over a period of time noise outputs average to zero. Clearly such a

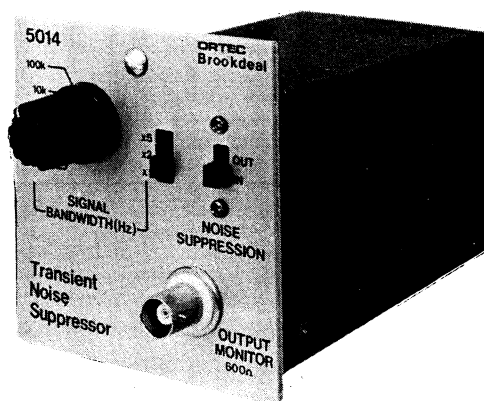

There are many experiments in which the leading edge of the signal waveform is perturbed by a high level impulse. By using suitable delay and control pulse forming circuits to drive the lock-in analyser gate input, the effects of such noise impulses may be suppressed.

## facilities

process will not discriminate against transients which occur on each cycle of the signal, and even incoherent high energy noise impulses will produce "a hump" in the averaged output. The signal gating facility is a means by which the signal path can be interrupted during the period of an interference impulse without undesirable transient side effects.

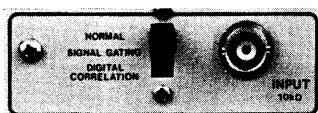

### 5.3.6 SIGNAL MONITOR

The ac signal at the input of the phase-sensitive detector may be monitored at the rear panel SIGNAL MONITOR socket.

### 5.4 response modes

There are four response modes available in the SC models, two in the C models and normal (squarewave) only in the 9503 and 9503D. In addition to the normal mode, the other responses available are sinetrac (fundamental only), analogue correlation and digital correlation.

Note that in sinetrac and analogue correlation modes the dynamic reserve specification is reduced by 10dB.

## operating instructions

The signal input to the demodulator can be blocked by the application of a high level (2V minimum) to the SC gating input. SIGNAL GATING is effective in any of the normal, SINETRAC and ANALOGUE CORRELATION modes. To use the signal gating facility, set the lower switch on the rear panel SC section to SIGNAL GATING and apply the gating signal to the INPUT socket. The gating signal should normally be at the second harmonic of the reference fundamental. In this way, information is gated from each half cycle of the signal waveform and no undesirable offsets are introduced in the output from the lock-in system.

Note that the signal is brought to the SIGNAL MONITOR socket through a 100:1 divider network. The maximum signal output is therefore approximately 250mV peak-peak.

A chart showing the modes available for each model and the correct switch settings and inputs for each mode is given below:

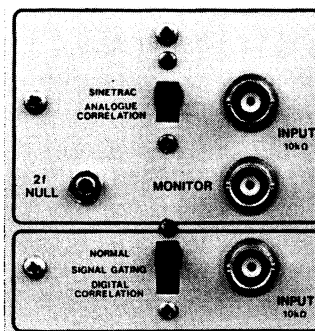

## facilities

response has the great benefit of avoiding often seemingly anomalous interference effects from noise at or near harmonic frequencies. In some cases sine response is essential and in many cases it will make the lock-in easier to use, with the reduction of interference leading to more consistent results. The system used in the 9503-SC, a sine waveform synthesizer followed by dynamic filtering, is particularly flexible as no range changes or other user adjustments are required - hence the name Sinetrac.

NB In this mode, measurement is made only at the fundamental frequency of the signal voltage. Thus, the output level will be different in SINETRAC mode from normal mode if the signal voltage is non-sinusoidal, e.g. if the signal is a squarewave, Sinetrac mode will give 81% of the output level obtained in normal mode.

A MONITOR output is available on the SC rear panel section and gives the output of the sine synthesizer. The 2f NULL control is provided so that the second harmonic response of the system can be adjusted.

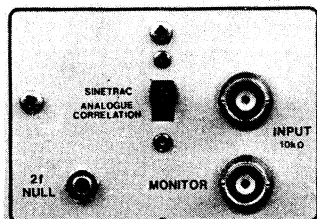

## operating instructions

are also experiments in which harmonics are generated, dependent on excitation level or the particular settings of the equipment under test: and in such cases a sine response is necessary.

To select SINETRAC mode, depress the front panel PWM pushbutton. On the rear panel SC section set the upper switch to SINETRAC and the lower switch to NORMAL (unless the signal gating facility is required - see section 5.3.5). The reference voltage may be of any form and is applied to the normal REFERENCE INPUT. All front panel facilities, including the precision phase shifter, are available (as in the normal mode).

In this mode the MONITOR output on the SC rear panel carries a 100mV rms sinewave phase-shifted by the 9503SC reference circuits relative to the original reference input. The 2f NULL control is factory-set to give optimum performance across the frequency range of the instrument and should require no further adjustment. Should the need arise, however, for example, to minimise second harmonic response in a particular frequency regime, the procedure for setting up is as follows;

Two oscillators are required. The first is tuned to the reference frequency of interest and applied to the 9503SC

Mode	Model	front panel pwm switch	(not fitted on standard models)		ref input used
			rear panel SC section upper switch	lower switch	
normal	all	out			
sinetrac	SC models	in	any	NORMAL	REF INPUT
an.corr.	C & SC models	in	SINETRAC	NORMAL	REF INPUT
dig.corr	SC models	out	AN.CORR.	NORMAL	corr.INPUT
			any	DIG.CORR.	gating INPUT

5.4.1 normal mode -  
applicable to  
all models

A normal (squarewave) response is that most frequently found in lock-in amplifiers. It gives a passband at the frequency of an in-phase reference and further passbands at odd harmonics: the gain at the 3rd harmonic is 1/3 of that at the fundamental, at the 5th 1/5 and so on. This has the effect of giving optimum signal recovery for a signal which is a squarewave accompanied by white noise. This mode allows the widest continuous frequency sweep over the full frequency range of the lock-in. In many cases this mode will give the least residual chop amplitude at the output for a given time constant, as well as the best gain and zero stability.

Select this mode for precision measurements in most optical experiments when high level discrete interference is not present.

To select this mode, do not depress the front panel PWM pushbutton. On the SC model select the NORMAL position on the lower of the 2 switches on the rear panel SC section (unless the SIGNAL GATING facility is required - see section 5.3.5). Use the normal REFERENCE INPUT for the reference voltage - see section 5.5 below.

5.4.2 SINETRAC mode -  
applicable to SC  
models only

A sinewave response has a passband at the fundamental frequency of an in-phase reference - regardless of the incoming reference waveform, and no material response at any harmonic frequencies. Sinewave

This mode is likely to be the most convenient one to use where there are no specific reasons to do otherwise. It is particularly beneficial for low frequency experiments, as explained opposite. There

facilities

operating instructions

REFERENCE INPUT in the usual way. The second oscillator is set to approximately the second harmonic of the reference input at a level of a few hundred millivolts rms and applied to the signal input.

Select    TIME CONSTANT        1ms  
          OUTPUT SMOOTHING    OFF

Monitor the final output of the lock-in on an oscilloscope and tune the second oscillator at around the second harmonic until a beat component appears in the output. Trim the 2f NULL control to minimise this beat component, increasing SENSITIVITY as required. The final trim may be made under conditions of up to 60dB overload in the signal channel.

#### 5.4.3 ANALOGUE CORRELATION mode - applicable to C & SC models

In this mode the reference signal addresses the demodulation section directly, by-passing the trigger and phase-shift circuitry. The response of the lock-in analyser is determined directly by the reference signal. In this mode it is possible to make unusually fast swept frequency measurements, while having a fundamental only response and maintaining accurate phase (no slew rate constraints of conventional lock-in reference channels). Also, since the gain of the analyser may be controlled by the amplitude of the reference signal, it is possible to make measurements which have hitherto not been possible with lock-in amplifiers.

This mode is of particular use if a matched filter response is required, or very fast swept frequency measurements have to be made. Each Fourier component in the reference waveform causes a passband in the system response with a gain proportional to the amplitude of that individual component - indeed if the reference waveform is sinusoidal, the instrument will have a fundamental only response.

To select this mode, depress the front panel PWM pushbutton. On the rear panel SC section set the upper switch to ANALOGUE CORRELATION and the lower switch to NORMAL (unless the signal gating facility is required - see section 5.3.5).



## facilities

Note that, as in SINETRAC, the frequency content of the signal and ANALOGUE CORRELATION reference should be limited to the range 2Hz to 25kHz (or 0.2Hz to 25kHz in mod 10 version). If the reference has the form of a digital signal, then the high harmonic content can be accommodated in the DIGITAL CORRELATION mode described in section 5.4.4.

The controls in the reference section on the front panel are disabled when ANALOGUE CORRELATION is selected and the front panel SENSITIVITY controls are calibrated when the ANALOGUE CORRELATION reference is set to 1V rms.

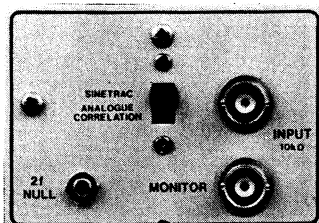

## operating instructions

The REFERENCE INPUT socket should not be used in ANALOGUE CORRELATION. Instead, the "any waveform" reference should be applied to the INPUT socket of the SC panel section. The MONITOR output is a scaled version of the applied reference waveform (at a level of -20dB).

A procedure for calibration is as follows:

- 1) Connect the "any waveform" reference, nominally 1V rms, to the INPUT socket on the SC panel.
- 2) Connect the MONITOR output from the SC panel (20dB below INPUT) to the SIGNAL INPUT of the instrument, 'A' input selected.
- 3) Select SENSITIVITY of 100mV. Signal channel FILTERS, TIME CONSTANT, etc. should be set appropriate to the reference frequency as in the conventional lock-in.
- 4) Trim the amplitude of the applied reference until the lock-in gives fullscale (10V) output.

In the event that the reference amplitude cannot be increased to give 1V rms, note that the calibration of the system is directly proportional to reference amplitude. In the procedure described above, however, 'reference' and 'signal' will vary together in amplitude so that the system will effectively have a square-law response, that is, reducing the reference input to 100mV rms will reduce the lock-in output to 1/100 of fullscale.

facilities

operating instructions

5.4.4 DIGITAL CORRELATION  
mode - applicable  
to SC models only

This mode is optimised for use with narrow pulse signals accompanied by white noise or interference near the signal frequency.

The reference signal is connected directly to the buffered demodulator whose configuration is changed. In this mode the time during which the demodulator samples the input noise is effectively reduced. The result is an improvement in signal recovery for a given measurement time.

NB The output in digital correlation mode is inverted.

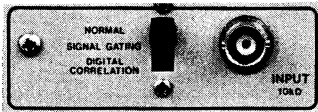

This mode should not be selected when the PWM pushbutton is depressed. DIGITAL CORRELATION gives optimum signal recovery when the signal has the form of a digital pulse train. Minimum pulse width is 10µs.

To select this mode, do not depress the front panel PWM pushbutton. On the rear panel SC section, the setting of the upper switch is unimportant; the lower switch must be set to DIGITAL CORRELATION.

The digital reference signal should be applied to the lower INPUT socket on the SC rear panel section with a minimum pulse amplitude of 2V for effective triggering. As the 9503SC reference channel is disabled in this mode of operation, the front panel phase-shift controls are inoperative. The SENSITIVITY calibration remains valid in DIGITAL CORRELATION except that proper allowance should be made for the structure of the digital waveform.

5.5 reference channel  
(normal & Sinetrac  
modes only)



5.5.1 REFERENCE INPUT

The REFERENCE INPUT accepts frequencies between 2Hz and 100kHz; the waveform may be of any shape provided it crosses its mean level once in each direction per cycle and the time between successive crossings of the trigger level must be

Connect the reference voltage to the REFERENCE INPUT socket on the rear panel, making sure that the REF LOW indicator on the front panel goes out.

greater than 500ns.

The reference input trigger circuits are isolated electrically from the remainder of the instrument in order to reduce the effect of reference ground currents. The reference input can be grounded if required by setting the ground/isolate switch to the  position.



A 3-position trigger MODE switch on the rear panel allows optimum jitter-free performance for sinewave and squarewave (or pulse) reference inputs. In  or  positions the trigger level is at 100mV above/below the mean level respectively.

In AUTO mode the reference circuit triggers at the mean level of the waveform. An arm/fire sequence ensures unambiguous triggering off both positive and negative pulses as well as accurate mean sensing in the AUTO mode.

### 5.5.2 PHASE adjustment

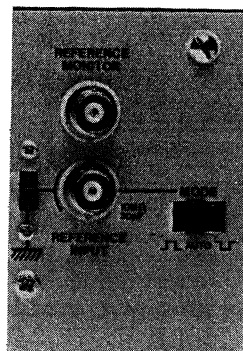
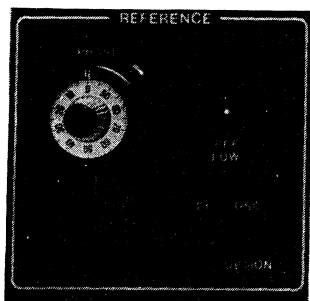
Using the 90°, 180° pushbuttons and the -5° to +95° continuous control, calibrated phase adjustments may be made.



Select AUTO trigger MODE for waveforms except pulse inputs. Select  for triggering off the positive-going edge of a squarewave or pulse input and  for triggering off the negative going edge.

Check that the ZERO OFFSET control is switched off.

Use the continuous PHASE control and the 90° pushbutton if necessary to set the output to zero (this can be achieved very accurately by making use of the EXPAND facility).

Change phase by 90° by means of the 90° pushbutton to give maximum output (remember first to switch EXPAND off if this was used to set zero above). Select the required output polarity by changing phase (if necessary) by 180°.

facilities

operating instructions

5.5.3 2nd harmonic measurement

A front panel pushbutton labelled 2F may be used to cause the reference channel to operate at twice the frequency of the reference input. In this mode all facilities are the same as for fundamental measurements.

For measurement of the second harmonic of a signal with the 9503, simply press the 2F selector button. Check the LOW PASS FILTER setting and make sure that it does not have an unwanted effect at the measurement frequency. Depending on the experimental circumstances, it may be necessary to adjust the PHASE control settings, as described in section 5.5.2 above.

In those situations where the amplitude of the second harmonic signal is smaller than that of the fundamental by more than an order of magnitude, the rejection of the fundamental by the instrumentation is important. The 9503 without signal channel filtering rejects the fundamental by a factor of more than 1000 times (>60dB). In many instances this is sufficient. However when greater rejection is required, insertion of the 5011F active filter (see section 5.3.3) can give total effective rejection approaching 100,000x (100dB).

Such rejection is in practice rarely useable since the modulation waveform often contains second harmonic components which are indistinguishable from the experimentally derived second harmonic signal of interest. It is recommended therefore that the modulation waveform is derived from a sinewave generator having exceptionally low second harmonic distortion such as the option oscillator model 5012F.

5.5.4 EXTERNAL PHASE control

It is possible to shift phase externally by applying a control voltage to the EXTERNAL PHASE input socket on the rear panel. The shift in phase is  $10^\circ/V$  and adds to the PHASE control settings on the front panel.

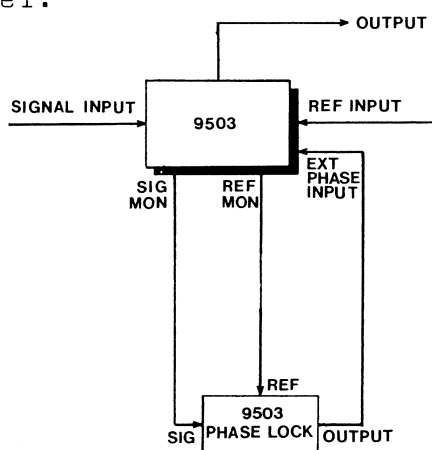

The EXTERNAL PHASE control facility is very suitable for vector track applications where the phase variation is not greater than  $100^\circ$ . The 9503 can simply be converted to a vector voltmeter mode by the addition of a second 9503 (with the phase set in quadrature to the other lock-in). A block diagram of a suitable experimental arrangement is shown opposite. Set the external phase control switch to on.

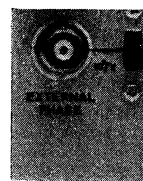

5.5.5 REFERENCE MONITOR

A rear panel REFERENCE MONITOR socket provides a 1.5V p-p output of the reference switching waveform at the input to the psd circuits.

In normal mode, if there is any doubt as to the frequency at which the reference is triggered, the REFERENCE MONITOR may be connected to an oscilloscope or frequency counter.

5.6 demodulator and output

This section contains five controls; the MODE control (which provides up to ten times fullscale zero suppression), the single section switched TIME CONSTANT control, the two section (12dB/octave) OUTPUT SMOOTHING pushbuttons and the DISPLAY BUS pushbutton.

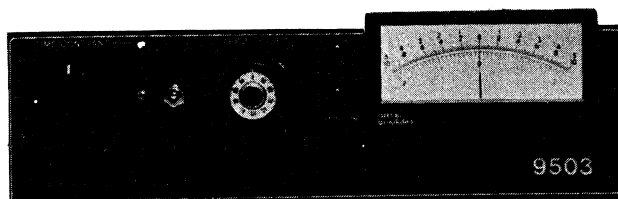

facilities

operating instructions

### 5.6.1 MODE

Three MODES are available on the 9503 family; HIGH STABILITY, HIGH RESERVE and PHASE LOCK.

The HIGH STABILITY and HIGH RESERVE modes between them provide an interchange of ac and dc gain in order to give a choice between dynamic reserve (overload capability) and output zero stability, depending on the application. The PHASE LOCK mode is for use in those applications where no reference voltage is available.



Select one of the MODES, as required, by depressing the appropriate front panel pushbutton.

#### a) HIGH STABILITY/HIGH RESERVE

Varying degrees of overload capability against output zero stability can be obtained by different combinations of the HIGH STABILITY mode, HIGH RESERVE mode and EXPAND settings (see 2.6.2 and 2.6.3, page 5). Select the MODE/EXPAND combination which accommodates the worst expected signal input overload conditions whilst giving the best output zero stability. Note that when the HIGH STAB mode is selected, the TIME CONSTANT settings are multiplied by 0.1 (indicated by the green led) to give a range from MIN (~20 $\mu$ s) to 10s.

To obtain optimum performance in output noise level, stability etc, EXPAND mode should not be selected unless required. In any event, when sensitivities less than 20mV are required, HIGH STAB mode should be used.

#### b) PHASE LOCK

The PHASE LOCK mode is for use in those applications where a reference voltage is not available. A block diagram of a suitable experimental arrangement is shown opposite. The output of the 9503 is connected to the voltage control input of a suitable oscillator (eg the Brookdeal model 9473), the output of which supplies the reference voltage for the lock-in amplifier. A 2nd 9503 (with phase set in

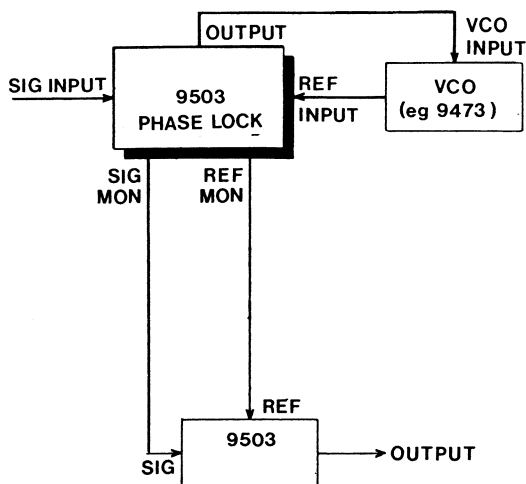

facilities

operating instructions

quadrature to the first) may be used to measure the magnitude of the signal of interest.

### 5.6.2 ZERO OFFSET

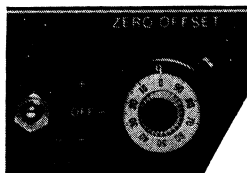

For the measurement of small changes in signal level, the ZERO OFFSET control may be used to suppress output for signals up to  $\pm 10 \times \text{fsd}$  (EXPAND on),  $\pm 1 \times \text{fsd}$  (EXPAND off).

### 5.6.3 TIME CONSTANT and OUTPUT SMOOTHING

The 9503, like any other lock-in amplifier, is a frequency selective voltmeter whose centre frequency is the same as the reference voltage applied to it. Its frequency range is the range of centre frequencies over which its sensitivity to signals at the centre frequency lies within  $\pm 0, -3\text{dB}$  of some nominal value. The frequency range of the standard 9503 is 2Hz to 100kHz. Within that frequency range however the 9503 has an overall response of a bandpass filter centred at the reference frequency. The bandwidth of this response is defined in terms of an equivalent flat-topped, vertical-sided bandpass filter. This is called the noise-equivalent bandwidth,  $\Delta f_{\text{en}}$ . This bandwidth is independent of the reference frequency and depends only on the time constant of the output filter. The longer the time constant, the longer the system response time but the smaller the

The following considerations may be helpful in choosing a TIME CONSTANT setting:

- 1) Chart recorders and X-Y plotters have response times between 50ms and 300ms. In general, therefore, the minimum useful TIME CONSTANT setting would be 100ms. Longer time constants should be selected to reduce noise, consistent with the response time requirements of the experiment.
- 2) Most economic dvm's and dmm's have conversion times in the region of 100ms and thus the minimum useful TIME CONSTANT would be 100ms.
- 3) In fast scan systems where the readout equipment may be an oscilloscope or multichannel memory (ie signal averager or MCA plus v-f converter) the output filtering is used, not so much for noise reduction as to remove modulation ripple.

The TIME CONSTANT should be selected to give maximum attenuation of the ripple consistent with the risetime

## facilities

bandwidth and less the noise. For single section 6dB/octave, low pass filter of time constant T, the noise bandwidth is given by:-

$$\Delta f_{en} = \frac{1}{4T} \text{ Hz}$$

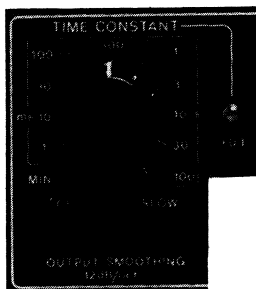

The output noise is therefore determined by the TIME CONSTANT.

**NB** The TIME CONSTANT value changes by a factor of 10 when the HI-DYN/HI-RES mode is changed. This is indicated by the green led.

The time constant control gives values from MIN (approx 20 $\mu$ s) to 10s in HIGH RESERVE MODE and MIN (approx 20 $\mu$ s) to 100s in HIGH STAB MODE.

## operating instructions

requirements imposed by the scan speed. For users of the 9503 in such applications, the following aids can be useful:

a) A capacitor placed across the appropriate socket of the 9503 would increase attenuation of the ripple without a proportionate increase in risetime. Use these values:

TIME CONSTANT	cap value
MIN (HI RES)	0.015 $\mu$ F
MIN (HI STAB)	0.0015 $\mu$ F
1ms	0.1 $\mu$ F
10ms	1.0 $\mu$ F

b) The OUTPUT SMOOTHING switched filter can be factory modified to provide added two section filtering with the corresponding time constants FAST 100 s  
SLOW 1ms

c) A dramatic improvement in ripple attenuation can be observed without increasing the filtering if the signal is a squarewave rather than a sinewave, provided that the 9503 is operated in a completely broad band manner. This is due to the fact that an ideally rectified squarewave contains no ripple. In many experimental systems it is only necessary to switch from sine to square modulation to obtain this benefit.

4) The purpose of the OUTPUT OVERLOAD indicator is to give warning of noise voltages at the phase sensitive detector output or at the output of the expand amplifiers which are sufficiently great to cause non-linearity. The correct remedy for this condition is to increase the TIME CONSTANT



## facilities

In some experimental situations a low frequency 'ripple' can become present at the output due either to a beat occurring between an interference signal and the reference or simply to the fact that the basic modulation frequency of the experiment is low. In either case this beat may be significantly attenuated by using the OUTPUT SMOOTHING filter without a proportionate increase in the system response time.

### 5.6.4 output overload

An OUTPUT OVERLOAD indicator is provided to give warning of noise voltages at the phase sensitive detector output or at the output of the expand amplifiers which are sufficiently great to cause non-linearity.



### 5.6.5 OUTPUT connection

The analogue output of the 9503 gives  $\pm 10V$  from  $10k\Omega$ .

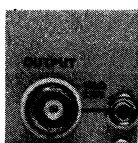

## operating instructions

setting until the indication is removed.

If the ripple is in the region 10Hz or greater, use the FAST position and, for frequencies lower than 3Hz, use the SLOW position. In between, either may be used depending on the severity of the ripple and the response time constraints. OUTPUT SMOOTHING should also be used when the frequency of operation is  $< 10Hz$ . (This is not advisable in certain applications, eg servo systems).

The OUTPUT OVERLOAD indicator will light when the meter is off-scale. The meter may be off-scale due to incorrect setting of the ZERO OFFSET control or too much SENSITIVITY/EXPAND.

Indication of OUTPUT OVERLOAD when the meter is on-scale indicates excessive noise voltages at the phase sensitive detector output. Increase the TIME CONSTANT setting until the indication is removed.

The OUTPUT may be connected directly to most equipment having input levels of  $\pm 10V$  dc fullscale. In the case of fixed high sensitivity chart records, a shunt resistor may be placed across the recorder input terminals, eg for 10mV fsd sensitivity a  $10\Omega$  resistor would be suitable.

## facilities

A rear panel zero adjust control is provided so that the output zero can be accurately set or re-set after carriage, ageing, operation in a high temperature environment, etc.

### 5.6.6 digital output - applicable to 'D' versions only

In the D versions, a digital output and display is available. The output format is parallel BCD, 3½ digit TTL compatible. A 2-pole low pass filter may be selected to give added smoothing at the input to the ADC. The sample rate is adjustable from 20 samples/s to 1 sample per 10s.

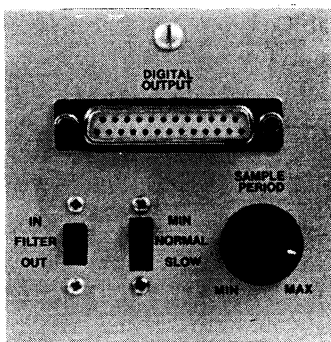
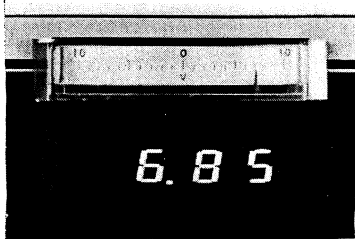

## operating instructions

To adjust zero accurately:-

- 1) short circuit the SIGNAL INPUT
- 2) set SENSITIVITY/EXPAND to 500mV
- 3) supply reference of frequency  $\leq 200\text{Hz}$
- 4) connect the OUTPUT to a dvm and set the screwdriver adjust ten-turn control to read zero on the dvm.

Adjust the SAMPLE PERIOD to a suitable setting.

Select FILTER IN if required. Connect the 25 way D socket to the peripheral as follows:

<u>Pin no</u>	<u>Function</u>
1	'2'
2	'4'
3	'8'
4	'10'
5	'20'
6	'40'
7	'80'
8	'100'
9	'200'
10	'400'
11	'800'
12	'1000'
13	not used
14	'1'
15	0V
16	0V
17	0V
18	+5V
19	+5V
20	+5V
21	peripheral in low
22	peripheral command
23	ready info out
24	minus
25	not used

When connected to a printer, hand shaking is accomplished by connecting 'ready info out' (pin 23) to the print command input on the printer and 'peripheral command' (pin 22) to the ready output on the printer. To enable hand shaking to take place 'peripheral in low' (pin 21) is connected to 0V.

### 5.6.7 DISPLAY BUS

A bus network connects optional slot-in outputs to the analogue meter display.

In D versions the digital display continues to monitor the output voltage while the edge-wise analogue meter shows the BUS output when selected.



Outputs of certain of the slot-in options may be displayed on the meter. A 3-position switch on the slot-in selects BUS1, BUS2 or off. If BUS 1 is selected and the front panel DISPLAY BUS pushbutton is pressed, the analogue meter shows the output voltage from that slot-in. Detailed instructions for the operation of each slot-in option are given separately.

### 5.7 option OSCILLATOR model 5012F

The 5012F slot-in oscillator provides a convenient source of high purity sinewaves for modulation in such applications as Auger, epr, nmr spectroscopy, ac bridge null detection, Hall effect studies, ac polarography, C-V measurements of semiconductors, etc. The amplitude of the output of the 5012F is controllable by means of a panel mounted control from 50mV to 5V rms. The 5012F automatically triggers the reference channel when it is switched on by the front panel OSC OPTION pushbutton.

Before fitting, switch off the 9503 and disconnect from the line supply.

Remove the rear panel blanking plate nearest to the 9503 power input panel (on right hand side looking from the rear) and the one next to it. Inside the instrument is the edge of a horizontally mounted component board and on it an orange 10-way plug (see page 52). Connect the orange 10-way socket on the flying lead of the 5012F into this plug: keyways in the plug and socket will prevent incorrect polarisation. Insert the body of the 5012F

facilities

operating instructions

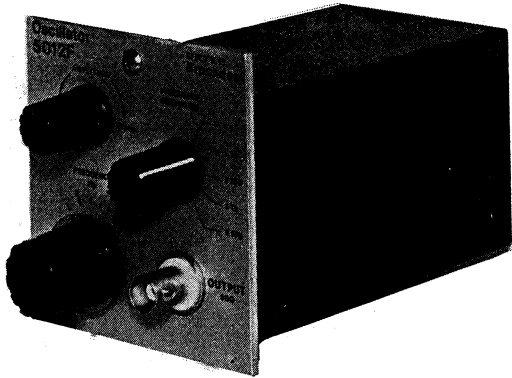

into the space left by the blanking panel, pushing the bottom edge of the 5012F panel into the slot in the lower extrusion. Push the top edge of the panel against the top extrusion and tighten the captive fixing screw.

To operate the oscillator, depress the front panel OSC OPTION pushbutton. The reference connection for the 9503 is made internally, automatically, in either normal or SINETRAC mode. Internal connection is not made in either of the correlation modes.

5.8 the OMNIPHASE option model 5042 - for installation instructions see section 5.11, page 51

The OMNIPHASE converts two 9503's to a "phase insensitive amplifier" mode of operation.

A block diagram of a suitable experimental arrangement is shown below.

The 5042 is an arithmetic unit which has two inputs A and B and two outputs termed 'modulus' and 'phase'. The modulus output is equal to  $\sqrt{V_A^2 + V_B^2}$  where  $V_A$  and  $V_B$  are the voltages applied to inputs A and B.

The purpose of the 5042 is to convert the resolved components of a two-phase lock-in amplifier  $V_s \cos \phi$  and  $V_s \sin \phi$  to the vector magnitude  $V_s$ . (NB the 5042 is applicable only for those cases when the signal input to the lock-in is a sinewave. For squarewave signals either the 5011F bandpass filter or sinetrac mode must be selected).

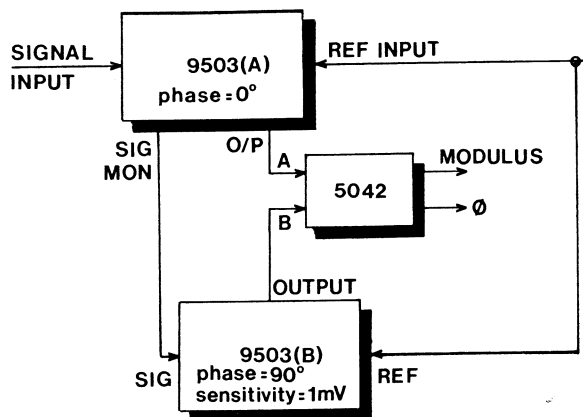

Connect OUTPUT (A) and OUTPUT (B) to INPUT A and INPUT B on the 5042.

Set either the bus MOD switch or the bus Ø switch to BUS1, as required.

When the 9503 front panel

facilities

Thus if  $V_A = V_S \cos \phi$  and  $V_B = V_S \sin \phi$  then the modulus output

$$= \sqrt{V^2 \cos^2 \phi + V_S^2 \sin^2 \phi}$$
$$= V_S$$

An ancillary output approximating to  $\tan^{-1}(V_S \sin \phi / V_S \cos \phi)$  may be used to monitor the phase angle.

Thus, by process of continuous computation the 5042 separates automatically the amplitude resultant from the resolved quadrature components. It has no phase 'dead zones' and therefore requires no setting up or quadrant selection. Either output can be monitored on the front panel meter by means of the BUS system in the 9503.

operating instructions

DISPLAY BUS switch is pressed, the meter will then show either the modulus or phase of the input signal voltages as selected (note: 0.36 fsg on the meter represents  $360^\circ$ ). NB the PHASE output is switched off if the modulus output falls below 100mV.

More detailed instructions are given in the 5042 instruction manual.

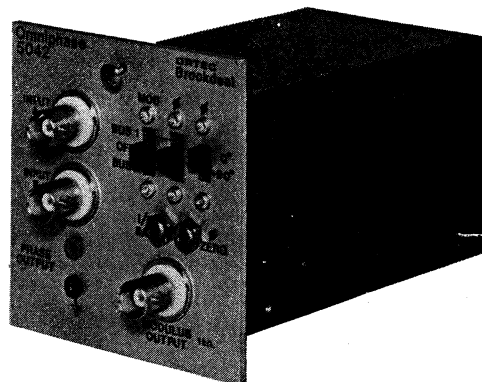

5.9 the RATIO METER  
option model 5047 -  
for installation  
instructions see  
section 5.11, page 51

The 5047 is an analogue arithmetic unit which has three inputs, A, B and C. Its output voltage is equal to  $(V_A - V_B) / |V_C|$ , where  $V_A$  and  $V_B$  are the voltages applied to inputs A and B and  $|V_C|$  is the modulus of the voltage applied to input C.

In optical experiments where errors can be caused due to source intensity, fluctuations real-time corrections are made possible by the 5047:

Connect the lock-in output to either the A or B INPUTS on the 5047 as required. Connect the 2nd channel of information as necessary.

Set the bus switch on the 5047 panel to BUS 1 so that by pressing the DISPLAY BUS switch on the 9503 front panel, the display will show the ratiometer output.

More detailed instructions are given in the 5047 instruction manual.

a) in the measurement of transmission the signal from the 'sample' beam is fed into the A input and that from the 'reference' beam into the C input; the output is a direct measure of transmission.

b) in the measurement of absorption the signal from the 'sample' beam is fed into the B input and that from the 'reference' beam into both A and C inputs; the output is a direct measure of absorption.

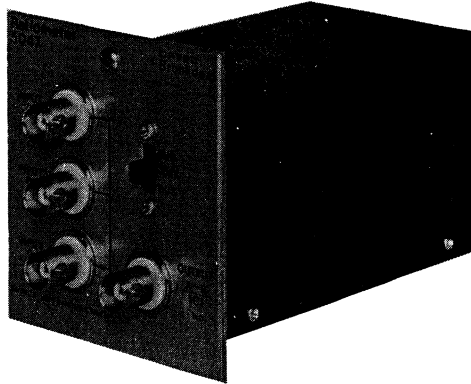

5.10 the NOISE MEASUREMENT  
UNIT option model 5049 -  
for installation  
instructions see  
section 5.11, page 51

The 5049 is a module which extends the capability of the lock-in amplifier to measure noise voltages in the frequency range 10Hz to 100kHz (200kHz in mod 11 version).

The noise measurement system uses the narrowband filter capability of a lock-in amplifier to define a measurement bandwidth centred on the applied reference frequency. This bandwidth is controlled by the lock-in TIME CONSTANT control. The noise-bandwidth of a lock-in with 6dB/octave time constant is  $1/4T$ , for a 12dB/octave time constant it is  $1/8T$ .

Since noise measurements can be carried out even in the presence of a coherent signal, the system allows independent and simultaneous measurement of a signal and its associated

Connect the OUTPUT of the lock-in to the INPUT of the 5049.

Set the BUS switch on the 5049 to BUS1 so that by pressing the front panel DISPLAY BUS pushbutton, the analogue meter will show the noise measurement unit output.

The noise measurement bandwidth is established by the TIME CONSTANT control with the OUTPUT SMOOTHING switched OFF. The noise bandwidth is related to selected TIME CONSTANT as follows:

$$\Delta f = \frac{1}{4T} (6\text{dB/octave}) \text{ or}$$

$$\Delta f = \frac{1}{8T} (12\text{dB/octave})$$

The SMOOTHING control on the 5049 is labelled FAST, MEDIUM, SLOW, corresponding to smoothing time constants of 1s, 10s and 100s. The smoothing is most effective on the larger noise

noise.

The noise output from the lock-in is ac coupled to a precision rectifier and low-pass filter circuit. AC coupling is used so that the dc outputs from the lock-in due to coherent signals do not affect the noise measurement.

A three position low-pass filter is provided to smooth the rectified noise output.

The gain of the 5049 is arranged so that the noise measurement sensitivity is 10x the sensitivity of the lock-in amplifier. The maximum sensitivity for fullscale (10V) output is 100nV rms. This choice of gain is most useful when measuring the noise associated with relatively clean signals.

bandwidths and should be selected to give an acceptable fluctuation in the indicated noise reading. The table shows the smoothing required to give better than 2% rms fluctuation in an indicated noise reading.

TIME CONSTANT	$\Delta F$ Hz	SMOOTHING TO GIVE <2% rms FLUCTUATION
1ms	250	} FAST } } MEDIUM } } SLOW }
10ms	25	
100ms	2.5	
300ms	0.8	
1s	0.25	

When measuring noisy signals, care should be taken not to overload the signal channel. As a general rule, therefore, the lock-in should be operated with the minimum possible ac gain (minimum possible SENSITIVITY setting), using the EXPAND control to amplify the low bandwidth signal appearing at the demodulator output.

For further information, see the 5049 instruction manual.

5.11 installation instructions for the 5042, 5047 and 5049

The 5042, 5047 and 5049 may be fitted into the rear panel of the 9503.

NB If front panel control of any of the slot-ins is required or if there is insufficient space available on the 9503 rear panel for the chosen selection of slot-ins,

Check that the 9503 is switched off and disconnected from the line supply. Remove the appropriate blanking plate(s) from the 9503 rear panel and the 4 screws securing the lid. Remove the lid. At the rear of the larger pcb are 2 white 10-way pressac plugs.

facilities

operating instructions

power bins are available (models 9597 and 9598) to provide power and connections for the slot-ins.

The sockets on the 5042/7/9 fit into either of the 2 white plugs. Keyways in the plugs and sockets will prevent incorrect polarisation.

Insert the body of the slot-in into the space(s) left by the blanking plates, pushing the bottom edge of the slot-in panel into the slot in the lower extrusion.

Push the top edge of the panel against the top extrusion and tighten the captive fixing screws.

brown pressac  
for 5011F

white pressacs  
for 5042,5047,5049

orange pressac  
for 5012F

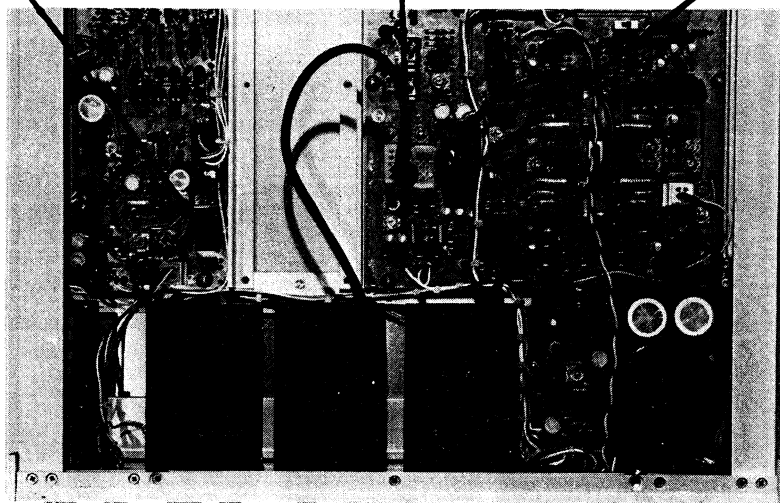

rear of  
instrument

#### 5.12 points to watch

The 9503 is a precision instrument with many extremely high performance features and specification. It is possible however to apparently degrade some points of specification if care is not taken with cables, choice of oscillator, etc. A guide to avoid some of the more common problems is given below.



### 5.12.1 signal/reference channel phase accuracy

In normal mode, PHASE difference between the signal and reference channels is specified as  $<1^\circ$  between 10Hz and 30kHz. The reference voltage must be sinewave preferably with 1V rms amplitude.

If absolute phase accuracy is important in the application, the following points should be observed.

- 1) use a low-distortion sinewave oscillator to drive the experiment and if possible a reference voltage level of 1V rms. Set REFERENCE input MODE to AUTO
- 2) use a T-piece to ensure that the oscillator drive to the experiment and the 9503 reference input are derived from the same source - do not rely on zero phase difference between 2 different outputs on the oscillator
- 3) at high frequencies ensure that signal and reference cable lengths are the same. For example, at 60kHz reference from a 600 $\Omega$  source, a difference of 1m in the signal and reference cable lengths can produce a phase difference of  $\sim 0.5^\circ$  (assuming cable capacitance of 30pF/m)
- 4) set 9503 HIGH and LOW PASS FILTERS well away from the modulation frequency (see section 5.3.2)
- 5) if a preamplifier is used at low frequencies ( $<10$ Hz), it is possible that the preamplifier could introduce some phase shift. If required, this can be adjusted to bring the signal/reference channel phase accuracy within  $1^\circ$  (down to 5Hz) for the total system (ie 9503 + preamp).

### 5.12.2 the FUNCTION CHECK facility

The FUNCTION CHECK facility is designed to provide a check on the 9503 controls (see section 5.2) and is not for use as a calibration check. The 9503 is calibrated during manufacture and in the normal course of events should not require further attention.

The check voltage is derived from the reference channel and is a 2mV p-p squarewave. Thus the test signal contains harmonics which can give anomalies in phase shift settings at low and high reference frequencies.

### 5.13 options - mod 10, 11, 13, 14

#### 5.13.1 extended frequency options, 10 and 11

The lf option, mod 10 extends the low frequency limit of the 9503 (all modes) to <0.2Hz. When this option is fitted, the MIN position of the LOW PASS FILTER switch becomes <0.2Hz.

This results in a degradation of the acquisition time and also the slew rate. Below 130Hz the slew rate specification becomes 220s/decade.

The hf option, mod 11 extends the high frequency limit of the 9503 (normal mode) to 200kHz. When this option is fitted the MAX position of the HIGH PASS FILTER switch becomes >200kHz.

It is recommended that the FUNCTION CHECK facility is used at or about 1kHz modulation frequency and in normal mode only. Accuracy of the 1mV level is then  $\pm 3\%$ . Amplitude accuracy and phase shift will be affected if the modulation frequency is above 10kHz or below 100Hz.

NB Ensure that the signal input voltage is disconnected when the FUNCTION CHECK facility is used.

Use the lf option when it is necessary to operate below 2Hz or in those applications where absolute gain and phase accuracy are important and the reference frequency is <10Hz.

It is recommended that the lf option is used only when necessary (as described above) - internal switches are provided so that the option can be switched out when not required. These 2 switches are mounted on the reference/demodulator board (see page 57).

Use the hf option when it is necessary to operate above 100kHz.

5.13.2 12dB/octave time constant, mod 13

When fitted, this option provides the choice of 6 or 12dB/octave roll-off on all TIME CONSTANT settings. When 12dB/octave roll-off is selected, the noise bandwidth is given by: (cf figure on page 44)

$$\Delta f_{en} = \frac{1}{8T} \text{ Hz}$$

The noise equivalent bandwidths for 6 and 12dB/octave are given in the following table:

MODE	HI-STAB	HI-RES
TIME CONSTANTS	20 $\mu$ s-10s	200 $\mu$ s-100s
$\Delta f_{en}$ - 6dB/oct	12.5kHz-25mHz	1.25kHz-2.5mHz
- 12dB/oct	6.25kHz-12.5mHz	0.63kHz-1.3mHz

5.13.3 demodulator monitor, mod 14

The demodulator monitor, when fitted, gives the demodulator output waveform at a level dependent on the dynamic reserve setting of the lock-in.

The demodulator monitor OUTPUT is from an impedance of 1k $\Omega$ , with a time constant of 1 $\mu$ s.

6 fault finding guide

6.1 introduction

The aim of this section is two-fold, first to assist the expert technician in fault diagnosis, secondly to supplement the detailed operating instructions laid out in chapter 5 to guide the user (who may not be an electronics specialist) through the difficulties which may occur when the instrument behaves in an unexpected way, either through malfunction or incorrect usage of the front panel controls.

In order to help the user find his way round the instrument, the basic 9503SC block diagram is shown in figure 3 in a form which approximates the internal layout of the instrument. The system incorporates four main printed circuit boards; the signal preamplifier, signal channel board, pulse carrier modulator board and reference/demodulator board, together with a power supply unit and the SINETRAC board which plugs into the pulse carrier modulator board.

The internal arrangement is shown in figure 4.

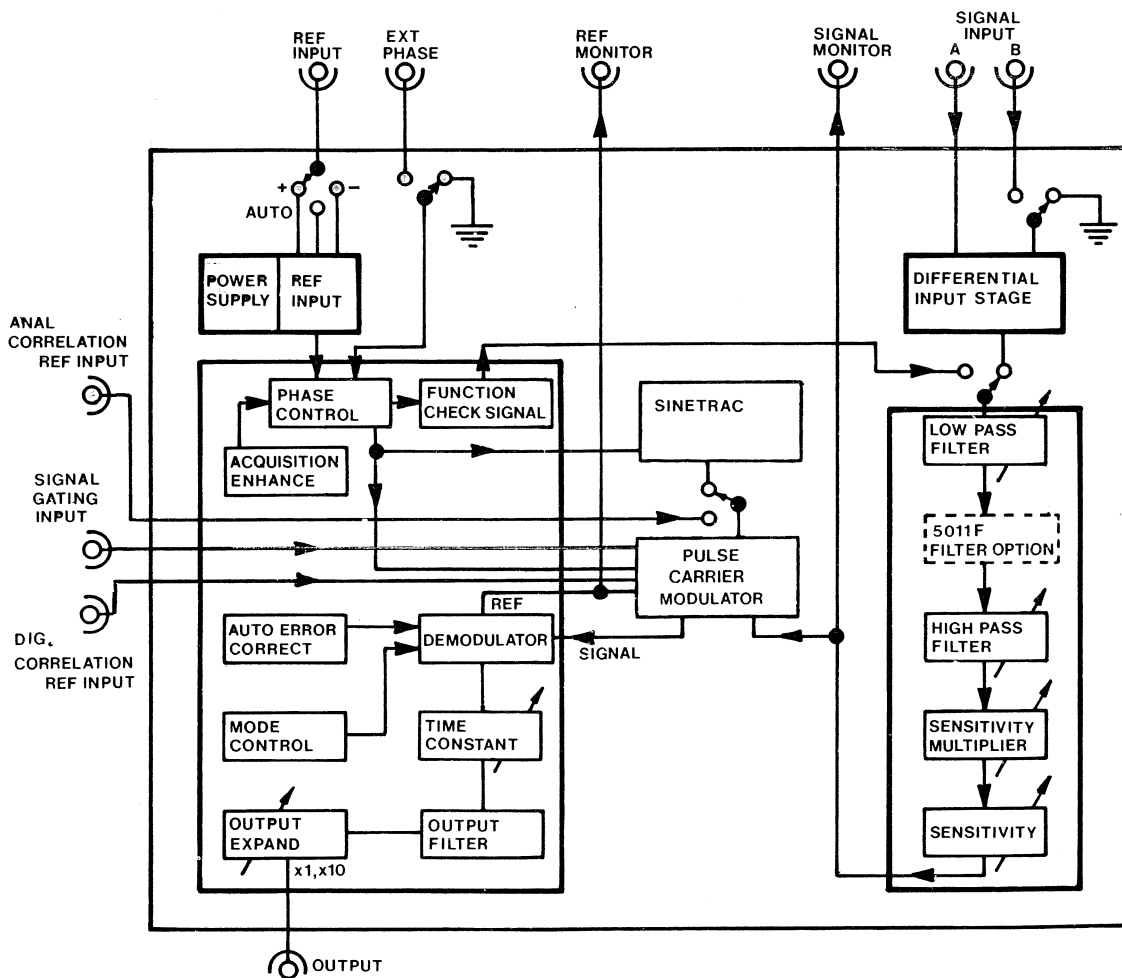

figure 3

power supply board

preamplifier board

mod 10 option  
lf switches

sinetrac board  
(SC versions only)

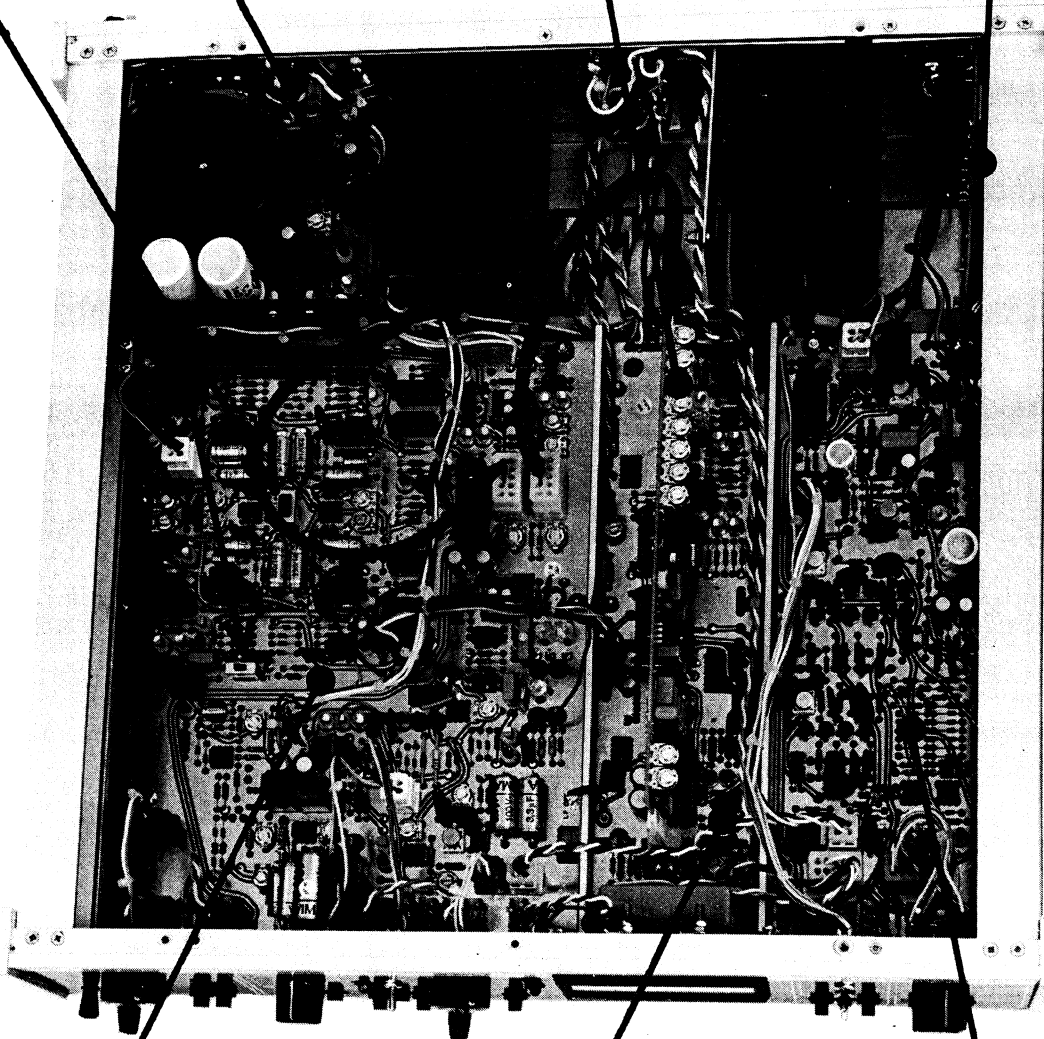

reference and  
demodulator board

signal channel board

pulse carrier modulator  
(correlation) board  
(C & SC versions)

figure 4

## 6.2 preliminary checks

The following procedure is a useful preliminary to fault finding and can be carried out with the minimum of test equipment.

- i) Connect to a suitable source of power, switch ON and leave to warm up with a short-circuit connected across the REF INPUT.
- ii) Check that the REF LOW indicator is alight.
- iii) In HI-STAB mode, check that the TIME CONSTANT  $\times 0.1$  led is alight and is extinguished when HI-RES mode is selected.
- iv) In the absence of signal, verify that positive and negative deflections can be obtained on the meter using the ZERO OFFSET control (check that DISPLAY BUS is not selected).
- v) Set for half-scale deflection in HI-STAB mode with EXPAND off. Depress the EXPAND button and check that the meter goes off-scale with the OUTPUT OVERLOAD led illuminated.

If all three indicators fail to illuminate in ii) - v), the instrument power supply has almost certainly failed. If using iv) and v), an OUTPUT OVERLOAD is indicated whilst no deflection is obtained on the meter, the output clamp circuit or final output amplifier has possibly failed.

## 6.3 power supply checks

Remove the red 4-way connectors which carry the output from the power supply to the main printed circuit boards (red socket 7 on signal board, red sockets 4 and 8 on reference/demodulator board), check fuse and correct selection of line voltage and switch ON.

Check that the supply delivers  $+15V \pm 50mV$  and  $-15V \pm 50mV$ . Check that the supply maintains its output when reconnected to the main printed circuit boards.

## 6.4 signal channel checks

With the signal channel filters set to MIN and MAX, the signal channel gain can be quickly checked out using a sinusoidal SIGNAL INPUT at 1kHz and observing the SIGNAL MONITOR output. The procedure is as follows:

- i) Select HI-STAB mode  
FILTERS, MIN, MAX  
SENSITIVITY,  $1\mu V/\times 10$   
SIGNAL INPUT A, 1kHz sinewave, 0.5mV rms

The SIGNAL MONITOR output should be a sinusoidal waveform of approximately 150mV p-p. Note that

- a) the gain of the signal channel does not depend upon the selection of EXPAND,
- b) on SC and C models the signal channel gain increases by 10dB (x3.16) when PWM is selected,
- c) on all models the signal channel gain falls by 20dB (x10) when HI-RES mode is selected.

The SIGNAL MONITOR output reproduces the waveform applied to the 9503 demodulator, except that the output is taken from a 100/1 divider network. If the output voltages in the following section fall to an inconveniently low level, then an alternative measuring point is at either end of C46 on the reference/demodulator board. A high impedance (1MΩ) oscilloscope probe should be used for this measurement.

- ii) Adjust the input to give 100mV p-p at the SIGNAL MONITOR output, then proceed as shown in the table below.

SENSITIVITY	MULTIPLIER	SIGNAL MONITOR OUTPUT VOLTS P-P	OUTPUT AT C46 VOLTS P-P
1μV 1μV 1μV	x10 x20 x50	100mV 50mV 20mV	10V 5V 2V
Increase input by 20dB			
10μV	x10	100mV	10V
Increase input by 20dB			
100μV	x10	100mV	10V
Increase input by 20dB			
1mV 10mV	x10 x10	100mV 10mV	10V 1V

Change MODE to HI-RES			
10mV	x10	1mV	100mV
10mV	x20	0.5mV	50mV
10mV	x50	0.2mV	20mV

The signal channel filters can be checked out by observing the roll-off at the SIGNAL MONITOR output. This applies also if the 5011F bandpass/notch filter option is installed.

### 6.5 reference channel checks

#### 6.5.1 introduction

Proper operation of the reference channel can be checked by observing the REFERENCE MONITOR output from the 9503SC. When normal "squarewave" response is selected, the output is a 1:1 squarewave, as shown in figure 5.

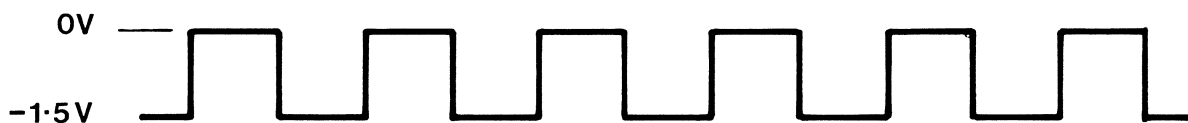

figure 5

The frequency of the output waveform should be the same as the input frequency and be double the frequency when the 2f button is depressed. If the output is displayed with a two channel oscilloscope, then the operation of the PHASE, 90° and 180° controls can be checked, together with the EXTERNAL PHASE input.

#### 6.5.2 SINETRAC mode (9503SC version only)

Select      PWM  
              SINETRAC  
              NORMAL or SIGNAL GATING      } rear panel SC section

The reference voltage (maximum frequency 25kHz) is applied to the REFERENCE INPUT socket. The output from the REFERENCE MONITOR socket is now a high frequency switching waveform with the ON and OFF times modulated at the frequency of the reference input. If the reference input is removed, the switching



waveform has the form of a pulse train at a frequency of about 100kHz.

The MONITOR socket - adjacent to the SINETRAC/ANALOGUE CORRELATION switch on the rear panel - monitors the waveform which is used to modulate the pulse carrier modulator. In SINETRAC mode the MONITOR socket shows a sinewave at a level of 300mV p-p. This is locked to the reference input waveform and can be shifted in phase relative to the reference input using the front panel controls.

#### 6.5.3 ANALOGUE CORRELATION mode (C & SC versions)

The analogue correlation reference is applied directly to the pulse-carrier modulator. With no analogue correlation reference applied, the switching waveform on the REFERENCE MONITOR socket has 1:1 mark/space ratio at a frequency of approximately 100kHz. The mark/space ratio can be controlled by application of a dc voltage (in range  $\pm 3V$ ) or an ac voltage to the ANALOGUE CORRELATION input socket.

#### 6.5.4 DIGITAL CORRELATION mode (SC versions only)

In DIGITAL CORRELATION mode, the REF MONITOR output displays an inverted version of the waveform applied to the DIGITAL CORRELATION input socket. The voltage levels are those shown in figure 5.

#### 6.5.5 phase-shifting circuits

The phase-shifting functions are carried out using a total of four msg circuits. The table below summarises the outputs from these circuits for correct operation.

Note that all voltages should be monitored using a high impedance ( $1M\Omega$ ) oscilloscope probe.

Also, when checking phase performance over the bandwidth of the instrument, it is essential that the signal input and reference input are derived from the same source, for example, by using a potential divider from the test oscillator output. The phase specification of the instrument can only be checked satisfactorily when the test oscillator is known to have extremely low distortion (typically 0.005% at second harmonic).

msg	mark/space ratio	control	test point
1	1:1	fixed	IC4, pin 11
2	variable 1:1 to 3:1	PHASE dial, EXT PHASE input	IC7, pin 3
3	1:1 & 3:1	90° button	IC9, pin 11
4	1:1	fixed*	IC11, pin 11

\* Reverses phase with 180° button

#### 6.5.6 fast acquisition circuit

With the REF INPUT short-circuited, the output from the fast acquisition circuit at IC3 pin 3 should be HIGH (+15V) with the REF LOW indicator alight.

After applying a reference for a few seconds, IC3 pin 3 should switch to 0V and extinguish the REF LOW indicator.

#### 6.5.7 optional oscillator

If an optional oscillator 5012F is not installed, depressing the OPT OSC button should not affect the performance of the lock-in. With a 5012F installed, the oscillator output will always override an external REF INPUT with the PHASE controls and 2f circuit fully operative.

### 6.6 demodulator

#### 6.6.1 introduction

Although, in principle, the entire instrument can be checked out in FUNCTION CHECK mode, the fault finding routines in this section are based on a sinusoidal input to the signal channel, the reason being that the effect of unwanted distortion, clipping, etc is more noticeable on sinusoidal signals than on the squarewaves which are present in FUNCTION CHECK mode.

#### 6.6.2 phase-splitter

When operating with NORMAL "squarewave" response, the voltages generated by the phase-splitter on the reference/demodulator board are as shown in figure 6, in correct phase relation to the REF MONITOR output. The phase relations are of course independent of the front panel controls. All voltages should

be measured using a high impedance ( $10M\Omega$ ) oscilloscope probe.

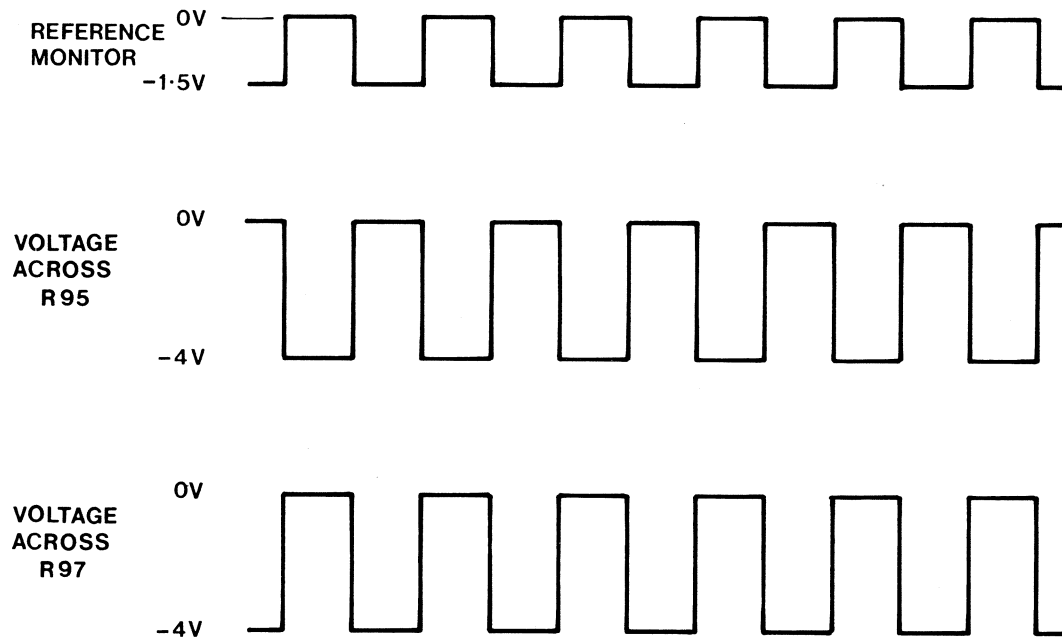

figure 6

### 6.6.3 demodulator waveforms

If too high a frequency is used to check out the demodulator, the switched waveforms observed will suffer a filtering effect in the low-pass filter sections. For this reason, the check-out procedure is given for a signal frequency in the range 30Hz to 100Hz with the TIME CONSTANT control in the MIN position, and NORMAL response mode.

Initially, the instrument should be set up with the following conditions:

SENSITIVITY	10mV/x10
EXPAND	off
FILTERS	MIN, MAX
MODE	HIGH STAB
OUTPUT SMOOTHING	OFF
ZERO OFFSET	OFF
TIME CONSTANT	1 sec
REF INPUT	1V rms approx
SIGNAL INPUT, A	100mV p-p

Adjust the phase controls to zero the output of the S503 then depress the 90° button. At this stage the instrument should give approximately one-third fullscale output. If this procedure is not possible owing to malfunction, set the phase

dial to zero and do not depress the 90° button.

Select TIME CONSTANT Min

Figure 7 shows the waveforms to be observed at the input and output of the demodulator. The output waveforms can be measured on any of the capacitors on the TIME CONSTANT switch using a 1MΩ oscilloscope probe.

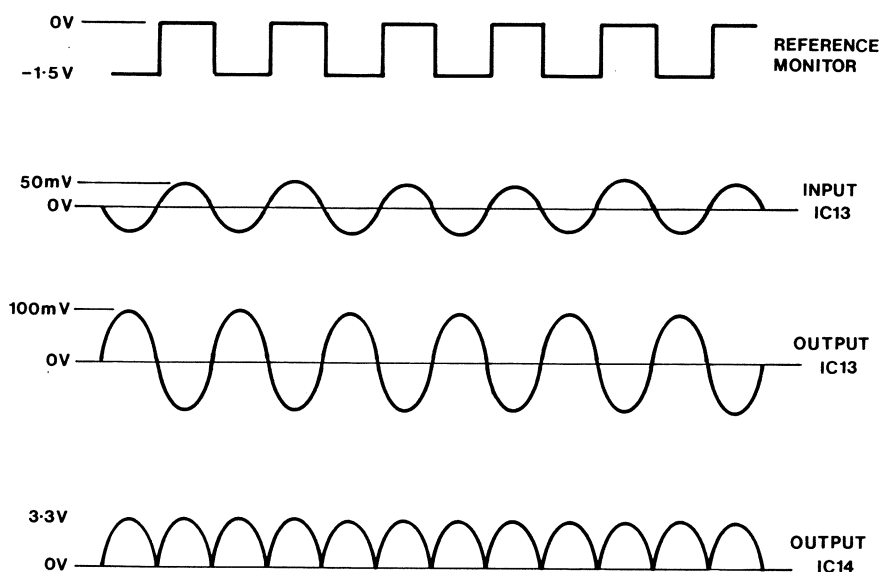

figure 7

The waveforms at the output of the demodulator should not change substantially when changing to HI RES mode, however, the signal channel gain will be reduced by a factor 10 with a corresponding reduction on the demodulator input waveforms shown in figure 7.

#### 6.6.4 output circuits

With the instrument set up as described in the last section, the voltage monitored on the output socket will be identical to that obtained from the demodulator output, except that an extra gain factor of 1.6 is supplied by IC16.

The effect of the OUTPUT SMOOTHING filter can be observed on this waveform.

Selection of EXPAND should be accompanied by an appropriate reduction in SENSITIVITY or in the signal level.

7 parts list

7.1 preamplifier board (all versions)

circuit ref	component value	tol %	volts wkg	power rtg.W	type	grade
R1	47k	5		$\frac{1}{8}$		
R2	15K	"		"		
R3	47k	"		"		
R4	100M	"		$\frac{1}{2}$		
R5	1k2	"		$\frac{1}{8}$		
R6	2k7	"		"		
R7	680	1		$\frac{1}{2}$		*
R8	470	"		"		*
R9	150k	5		$\frac{1}{8}$		
R10	680	"		"		
R11	470	1		$\frac{1}{2}$		*
R12	220	5		$\frac{1}{8}$		
R13	680	1		$\frac{1}{2}$		*
R14	10k	5		$\frac{1}{8}$		
R15	5k6	"		"		
R16	2k7	"		"		
R17	1k2	"		"		
R18	100M	"		$\frac{1}{2}$		
R19,20	2k7	1		"		*
R21,22	220	5		$\frac{1}{8}$		
R23	5k6	"		"		
R24	10k	"		"		
C1,2	0 $\mu$ 1		400		PMT2R	
C3,4	47p	5			S/M radial	
C5,6	100 $\mu$		16		CSB	
C7,8	0 $\mu$ 1		30		disc ceramic	
VC1,2	2-18pF				809-09003	
Q1-5					BC184LC	BX
Q6					BC214LC	AX
Q7&13					FM8	**
Q8,9					BC214LC	AX
Q10					BC184LC	BX
Q11,12					BC214LC	AX
Q14,15					BC214LC	AX
Q16,17					BC184LC	BX

circuit ref	component value	tol %	volts wkg	power rtg.W	type	grade
7.2	<u>signal channel</u> (all versions)					
R1,2	100k	5		1/8		*
R3	4k7	1		1/8		
R4-6	100k	5		1/8		
R7	10M	"		1/8		
R8	6k98	1		1/8		*
R9-11	10M	5		1/8		
R12-14	100k	"		1/8		
R15	75k	1		1/8		*
R16	8k25	"		1/8		*
R17	100k	5		1/8		
R18,19	10k	"		1/8		
R20	100k	"		1/8		
R21	3k0	1		1/2		*
R22	30k	"		1/2		*
R23,24	100k	5		1/8		
R25	10M	"		1/8		
R26-29	100k	"		1/8		
R30-31	30k	1		1/2		*
R32	10k	"		1/2		*
R33-34	30k	"		1/2		*
R35	10k	"		1/2		*
R37,38	4k7	"		1/2		*
R39,40	47K	"		1/2		*
R41-44	100k	5		1/8		*
R45	47k	1		1/8		*
R46,47	4k7	"		1/8		*
R48	470	"		1/8		*
R49	10M	5		1/8		
R50	43k	"		1/8		
R51	10	"		1/8		
R52	47	"		1/8		
R53	10	"		1/8		
R54	47	"		1/8		
R55,56	10	"		1/8		
R57	62k	"		1/8		
R58	620	"		1/8		
R59	15k	"		1/8		
R60	18k	"		1/8		
R61-66	15k	"		1/8		
R67,68	75k	"		1/8		
R69	680k	"		1/2		
R70,71	39k	"		1/2		
R72	680k	"		1/2		
R73	39k	"		1/2		
R74	5k6	"		1/2		
R75	22k	"		1/2		
R76,77	1k	"		1/2		
R78,79	10	"		1/2		
C1,2	0μ1		30		disc ceramic	
C3	10p	±1/2p			S/M radial	
C4	1000p	5			"	

circuit ref	component value	tol %	volts wkg	power rtg.W	type	grade
C5	0μ033	5	400		PMT2R	
C6-9	0μ1		30		disc ceramic	
C10	470μ		16		CSB	
C11	0μ68	5	100		PMT2R	
C12	0μ022	"	400		"	
C13	100μ		16		CSB	
C14,15	0μ1		30		disc ceramic	
C16	2p2	±½p			S/M radial	
C17	15p	"			"	
C18	0μ1		30		disc ceramic	
C19	15p	±½p			S/M radial	
C20	1000μ		16		CSB	
C21-28	0μ1		30		disc ceramic	
C29	3p9	±½p			S/M radial	
C30	4p7	"			"	
C31	12p	"			"	
C32	2p2	"			"	
C33	5p6	"			"	
C34	15p	"			"	
C36,37	0μ1		30		disc ceramic	
C38	2p2	±½p			S/M radial	
C39,40	47p	1			"	
C41	470p	5			"	
C42-45	0μ1		30		disc ceramic	
C46	27p	±½p			S/M radial	
C47-50	100μ		16		CSB	
C51	47μ		16		electrolytic	
C52	82p	5			S/M radial	
C53	10μ		35		electrolytic	
C54,55	0μ1		30		disc ceramic	
C56	1000p				"	
C57	0μ1		30		"	
C58,59	100μ		16		printilyt	
CV1	2-18p				809.09003	
D1-17					1N4148	
Q1					E112	
Q2					E112	*
Q3,4					E112	
Q5					E112	*
Q6-21					E112	
Q22					E112	*
Q23					BC214LC	AX
IC1-4					LM318H	
IC5,6					SN72748P	
SW1	FUNCTION CHECK switch				5.0104.00016	*
SW2	PWM OPTION switch				"	*
SW3	NOTCH/B'PASS OPTION switch				"	*
SW4	SENSITIVITY MULTIPLIER switches				5.0104.00028	*

circuit ref	component value	tol %	volts wkg	power rtg.W	type	grade
7.3	reference/demodulator board (all versions)					
R1,2	10k	5		$\frac{1}{2}$		
R3	68	"		$\frac{1}{8}$		
R4	270	"		"		
R5	680	"		"		
R6	100	"		"		
R7	330	"		"		
R8	100	"		"		
R9	220	"		"		
R10	680	"		"		
R11	10k	"		"		
R12,13	68k	"		"		
R14	27k	"		"		
R15	10k	"		"		
R16	680	"		"		
R17	560	"		"		
R18	100	"		"		
R19	330	"		"		
R20	100	"		"		
R21	680	"		"		
R22	100k	"		"		
R23	10k	"		"		
R24	4k7	"		"		
R25	470	"		"		
R26	10M	"		$\frac{1}{2}$		
R27	4k7	"		$\frac{1}{8}$		
R28	470	"		"		
R29	10M	"		$\frac{1}{2}$		
R30	1k	"		"		
R31	4k7	"		$\frac{1}{8}$		
R32	470	"		"		
R33	12	"		"		
R34	1k	"		"		
R35	33k	"		"		
R36	27k	"		"		
R37	6k2	"		"		
R38	10k	"		"		
R39	150k	1		$\frac{1}{2}$		*
R40	100k	5		$\frac{1}{8}$		
R41	270k	1		$\frac{1}{2}$		*
R42	15k	5		$\frac{1}{8}$		
R43	10M	"		$\frac{1}{2}$		
R44	100	"		$\frac{1}{8}$		
R45	100	1		$\frac{1}{2}$		*
R46	68k	"		"		*
R47	4k7	"		"		*
R48-50	4k7	5		$\frac{1}{8}$		
R51	470	"		"		
R52	12	"		"		
R53	1k	"		"		
R54	33k	"		"		
R55	27k	"		"		
R56	6k2	"		"		
R57	10k	"		"		



circuit ref	component value	tol %	volts wkg	power rtg.W	type	grade
R58	150k	1		$\frac{1}{2}$		*
R59	68k	5		$\frac{1}{8}$		
R60	270k	1		$\frac{1}{2}$		*
R61	15k	5		$\frac{1}{8}$		
R62	330k	1		$\frac{1}{2}$		*
R63	510k	"		"		*
R64	4k7	5		$\frac{1}{8}$		
R65	470	"		"		
R66	12	"		"		
R67	1k	"		"		
R68	33k	"		"		
R69	27k	"		"		
R70	6k2	"		"		
R71	10k	"		"		
R72	150k	1		$\frac{1}{2}$		*
R73	82k	5		$\frac{1}{8}$		
R74	270k	1		$\frac{1}{2}$		*
R75	15k	5		$\frac{1}{8}$		
R76	560k	1		$\frac{1}{2}$		*
R77	4k7	5		$\frac{1}{8}$		
R78	470	"		"		
R79	12	"		"		
R80	1k	"		"		
R81	33k	"		"		
R82	27k	"		"		
R83	6k2	"		"		
R84	10k	"		"		
R85	150k	1		$\frac{1}{2}$		*
R86	100k	5		$\frac{1}{8}$		
R87	270k	1		$\frac{1}{2}$		*
R88	15k	5		$\frac{1}{8}$		
R89,90	100k	"		"		
R91	4k7	1		$\frac{1}{2}$		*
R92	36k	5		$\frac{1}{8}$		
R93	4k7	"		"		
R94	10k	"		"		
R95	510	1		$\frac{1}{2}$		
R96	1k	"		"		
R97	510	"		"		
R98	5k1	5		$\frac{1}{8}$		
R99	10k	"		"		
R100,101	1k	1		$\frac{1}{2}$		
R102	2k2	"		"		*
R103	2M2	"		"		*
R104	22M	"		"		*
R105	1k5	"		"		*
R106	1k3	5		$\frac{1}{8}$		
R107	3k	"		"		
R108	3k	1		$\frac{1}{2}$		*
R109	820	5		$\frac{1}{8}$		
R110	270	"		"		
R111	27k	"		"		
R112,113	33k	1		$\frac{1}{2}$		*
R114	2M2	"		"		*

circuit ref	component value	tol %	volts wkg	power rtg.W	type	grade
R115	22M	1		1/2		*
R116-118	100k	5		1/8		
R119	3k9	"		"		
R120,121	11k	"		"		
R122	3k9	"		"		
R123	510k	"		1/2		
R124	1M	"		"		
R125	10k	"		1/8		
R126,127	68k	"		"		
R128	39k	"		"		
R129	220k	"		"		
R130,131	39k	"		"		
R132	5k6	"		"		
R133	22k	"		"		
R134	1k	"		1/2		
R135	10M	"		"		
R136	470	1		"		*
R137	10k	"		"		*
R138	8k2	"		"		*
R139,140	560k	5		"		
R141	11k	"		1/8		
R142	10k	"		1/2		
R143	82k	"		1/8		
R144	91k	"		"		
R145	9k1	"		"		
R146	6K2	"		"		
R147	680	"		1/2		
R148	10k	"		1/8		
R149	1k	"		1/2		
R150	2M2	"		"		
R151	22M	"		"		
VR1	470				90H	
VR2	100				"	
VR3	470				"	
VR4	47k				"	
VR5	2k2				"	
VR6,7	47k				"	
VR8	100k				"	
VR9	47k				"	
VR10	100k				"	
VR11	47k				"	
VR12	1k				"	
VR14	22k				"	
VR15	470				"	
VR16	22k				"	
VR17	100				"	
VR18	2k2				"	
VR19,20	22k				"	
VR21	2k2				"	
VR22	22k				"	

circuit ref	component value	tol %	volts wkg	power rtg.W	type	grade
C1,2	0μl		30		disc ceramic	
C3	100p	5			S/M radial	
C4	1000p	"	400		TFF	
C5	0μ22	"	100		PMT2R	
C6	2μ2	"	"		"	
C7	100p	"			S/M radial	
C8	470p	"	400		TFF	
C9,10	0μl		30		disc ceramic	
C11	22μ		16		electrolytic	
C12	1μ	5	100		TFM	
C13	0μl		30		disc ceramic	
C14	100p	5			S/M radial	
C15	10p	±½p			"	
C16	100p	5			"	
C17	470p	"	400		TFF	
C18	1000p		30		disc ceramic	
C19	0μl		"		"	
C20	22μ		16		electrolytic	
C21	1μ	5	100		TFM	
C22	100p	"			S/M radial	
C23	470p	"	400		TFF	
C24	1000p		30		disc ceramic	
C25	0μl		"		"	
C26	22μ		16		electrolytic	
C27	1μ	5	100		TFM	
C28	100p	"			S/M radial	
C29	470p	"	400		TFF	
C30,31	0μl		30		disc ceramic	
C32	22μ		16		electrolytic	
C33	1μ	5	100		TFM	
C34-36	100μ		16		CSB	
C37-40	220μ		"		electrolytic	
C41	0μl		30		disc ceramic	
C42	10p	±½p			S/M radial	
C43,44	0μl		30		disc ceramic	
C45	SIT					
C46,47	3μ3	5	100		TFM	**
C48	0μl		30		disc ceramic	
C49,50	100p	5			S/M radial	
C51	1μ	"	100		PMT2R	
C52	0μl	"	"		"	
C53	0μ47	"	"		"	
C54	0μ047	"	"		"	
C55	10μ		35		electrolytic	
C56	1μ	5	100		PMT2R	
C57,58	100μ		16		CSB	
C59	1000p				TFF	
C60	0μ22	5	100		PMT2R	
C61	33p	"			S/M radial	
CV1	2-18p				809.09003	
CV2-4	1.4-5.5p				809.09001	

circuit ref	component value	tol %	volts wkg	power rtg.W	type	grade
D1-28					1N4148	
Q1,2					BC184LC	A
Q3&8					FM5	**
Q4					BC184LC	A
Q5&7					TM2	**
Q6					BC184LC	A
Q9					BC184LC	A
Q10,11					BC214LC	AX
Q12&14					TM2	**
Q13					BC184LC	A
Q15-17					"	A
Q18					BC214LC	AX
Q19					BC184LC	A
Q20					BC214LC	AX
Q21					BC184LC	A
Q22					BC214LC	AX
Q23					BC184LC	A
Q24					BC214LC	AX
Q25					BC184LC	A
Q26,27					TM2	**
Q28,29					"	**
Q30					BC214LC	AX
Q31					BC184LC	BX
Q32,33					BC184LC	A
Q34					BC214LC	AX
Q35					2N3819	C
Q36					BC184LC	A
Q37,38					FM13	**
Q39-41						*
Q42					BC214LC	AX
Q43					BC184LC	A
Q44					BF244A	
Q45					BC214LC	AX
Q46,47						**
Q48					BC184LC	A
1C1-4					34001PC	
1C5					LM358N	
1C6,7					34001PC	
1C8					LM358N	
1C9-11					34001PC	
1C12					μA356TC	
1C13					LM318	
1C14					μA356TC	
1C15					LM1458N8	
1C16					LF356H	
SW1,2	internal lf switch				SSP42	
SW3	90° switch					*
SW4	180° switch					*
SW5	2f switch					*

circuit ref	component value	tol %	volts wkg	power rtg.W	type	grade
SW6	OSC OPTION switch					*
SW7	OUTPUT SMOOTHING switches					*
SW8	HIGH STAB MODE switch					*
SW9	HIGH RES MODE switch					*
SW10	PHASE LOCK MODE switch					*
SW11	EXPAND switch					*
SW12	DISPLAY BUS switch					*

#### 7.4 power supply board (all versions)

R1,2	2k2	5		$\frac{1}{8}$		
R3,4	33	"		"		
R5,6	470	"		"		
R7,8	1.2	"		2.5		
R9	8k2	1		$\frac{1}{2}$		*
R10	5k6	"		"		*
R11	2k2	"		"		*
R12,13	10k	"		"		*
R14	10M	5		"		
R15	1M	"		"		
VR1	1k				90H	
VR2	220				"	
C1,2	1000 $\mu$		35		CSB	
C3,4	6p8	$\pm\frac{1}{2}p$			S/M radial	
C5,6	1000 $\mu$		16		CSB	
ZD1					1N821	
BR1,2					W04	
Q1					TIP32A	
Q2					TIP31A	
Q3					BC214LC	AX
Q4					BC184LC	A
IC1,2					SN72748P	
TX1	line transformer				4.0910.21025	*
SW1	MODE switch				5.0107.00015	*

circuit ref	component value	tol %	volts wkg	power rtg.W	type	grade
-------------	-----------------	-------	-----------	-------------	------	-------

7.5 components not mounted on pcb's (all versions)

7.5.1 components on front panel

M1	meter				4.1011.31014	*
LED1	SIGNAL OVERLOAD led				3.0900.00400	*
LED2	OUTPUT OVERLOAD led				"	
LED3	REF LOW led				"	
LED4	x0.1 led				3.0900.00900	*
SW6,7	LOW-PASS, HIGH PASS FILTERS switch assembly				9.9503.13900	*
SW8	ZERO OFFSET switch assembly				9.9503.13500	*
SW9	TIME CONSTANT switch assembly				9.9503.13300	*
SW10	SENSITIVITY switch assembly				9.9503.13000	*
VR2	continuous PHASE control assembly				9.9503.13100	*
VR3	ZERO OFFSET control assembly				9.9503.13700	*

7.5.2 TIME CONSTANT switch

The following components are included with the switch assembly given under the appropriate part number in section 7.5.1.

R1	47k	5		$\frac{1}{8}$		
C11	4 $\mu$ 7	5	100		TFM	
C12	1 $\mu$ 5	"	"		"	
C13	0 $\mu$ 47	"	"		"	
C14	0 $\mu$ 15	"	160		"	
C15	0 $\mu$ 047	"	400		"	
C16	0 $\mu$ 015	"	"		"	
C17	4700p	"	"		TFF	
C18	1500p	"	"		"	
C19	470p	"	"		"	
C20	47p	"	"		"	

7.5.3 signal connections panel

R85	10	5		$\frac{1}{2}$		
VR1	10k CMR adjust				6.0110.00013	*

circuit ref	component value	tol %	volts wkg	power rtg.W	type	grade
SW1	A/A-B switch				5.0103.0006	*

7.5.4 power supply panel

VR4	100k zero set potentiometer				6.0110.00014	*
FS1	ac FUSE, 200mA				4.0302.01116	*
C7	0 $\mu$ 01	5	400		TFM	
C8	1000p		30		disc ceramic	
SW3	VOLTAGE SELECTOR switch				5.0107.0002	*
SW4	ground/isolate switch				5.0107.0003	*
SW5	external phase switch				"	*

7.5.5 other components

C1	1 $\mu$	5	100		PMT2R	
SW2	POWER switch				5.0104.00015	*

7.6 correlation board (C & SC versions only)

R1	3k9	1		$\frac{1}{2}$
R2	5k1	"		"
R3	1k	"		"
R4,5	1k2	"		"
R6	5k6	"		"
R7,8	680	"		"
R9	10	5		"
R10	10k	"		$\frac{1}{8}$
R11	1k2	1		$\frac{1}{2}$
R12	4k7	5		$\frac{1}{8}$
R13,14	2k2	"		"
R15,16	470	"		"
R17	3k3	"		"
R18	8k2	"		"
R19	4k7	"		"
R20	10k	"		"
R21	4k3	"		"
R22	10k	"		"

circuit ref	component value	tol %	volts wkg	power rtg.W	type	grade
R23	3k3	5		$\frac{1}{2}$		
R24	6k8	"		"		
R25	10k	"		"		
R26	2k2	"		$\frac{1}{8}$		
R27	3k9	"		"		
R28	10k	"		"		
R29	1k	"		"		
R30	10k	"		"		
R31,32	100k	"		"		
R33	560k	1		$\frac{1}{2}$		
R34-40	100k	5		$\frac{1}{8}$		
R41,42	10k	"		"		
R43	100k	"		"		
R44	10k	1		$\frac{1}{2}$		
R45,46	100k	5		$\frac{1}{8}$		
R47	31k6	1		$\frac{1}{2}$		
R48	10k	"		"		
R49	43k	5		$\frac{1}{8}$		
RV1	4k7				90H	
RV2	100k				"	
C1	1000p	5			S/M radial	
C2	10 $\mu$		35		electrolytic	
C3	27p	5			S/M radial	
C4-15	0 $\mu$ 1		30		disc ceramic	
C16	47p	5			S/M radial	
C17	3p3	$\pm\frac{1}{2}$ p			"	
C18	27p	5			"	
C19,20	100 $\mu$		16		CSB	
D1,2					1N4148	
ZD1-3					BZY88 C6V2	
ZD4					BZY88 C3V9	
Q1-3					BC184LC	A
Q4-7					BC214LC	V
Q8,9					BC184LC	A
Q10					BC214LC	AX
Q11-13					BC214LC	V
Q14,15						
Q16,17					E112	**
IC1					34086PC	
IC2,3					34001PC	
IC4					LM318N	



circuit ref	component value	tol %	volts wkg	power rtg.W	type	grade
7.7	<u>sinetrac board</u> (SC versions only)					
R1	2k2	1		$\frac{1}{2}$		
R2	13k	"		"		
R3	2k2	5		$\frac{1}{8}$		
R4	13k	"		"		
R5	2k2	"		"		
R6	1k	"		"		
R7	100k	"		"		
R8,9	4k7	"		"		
R10	10k	"		"		
R11-13	10M	"		$\frac{1}{2}$		
R14	15k	"		$\frac{1}{8}$		
R15	22M	"		$\frac{1}{2}$		
R16	82K	"		$\frac{1}{8}$		
R17	2k2	"		"		
R18	13k	"		"		
R19	2k2	"		"		
R20	1k	"		"		
R21	100k	"		"		
R22,23	4k7	"		"		
R24	10k	"		"		
R25-27	10M	"		$\frac{1}{2}$		
R28	15k	"		$\frac{1}{8}$		
R29	22M	"		$\frac{1}{2}$		
R30-33	3k3	1		"		
R34,35	8k2	"		"		
R36-45	5k6	"		"		
R46,47	13k	"		"		
R48	16k	"		"		
R49	18k	"		"		
R50	27k	"		"		
R51	68k	"		"		
R52	10k	"		"		
R53	4k7	"		"		
R54	2k2	"		"		
R55	2k	"		"		
R56	5k6	"		"		
R57,58	68k	5		$\frac{1}{8}$		
RV1	100				90V	
RV3	4k7				"	
RV4	470				"	
RV5-7	4k7				"	
RV8,9	10k				"	
RV10	47k				"	
C1,2	0 $\mu$ 015		400		PMT2R	
C3	0 $\mu$ 33		100		"	
C4	0 $\mu$ 1		"		"	
C5	0 $\mu$ 15		"		"	
C6,7	0 $\mu$ 015		400		"	
C8	0 $\mu$ 33		100		"	

circuit ref	component value	tol %	volts wkg	power rtg.W	type	grade
C9	0 $\mu$ 1		100		PMT2R	
C10	0 $\mu$ 15		"		"	
C12	4p7	$\pm 1/2$ p			S/M radial	
C13,14	100		16		CSB	
D1-10					1N4148	**
D11,12					"	**
D13,14					"	**
D15,16					"	**
D17,18					"	**
D19,20					"	**
D21,22					"	**
Q1					BC184LC	A
Q2					E112	
Q3,4					BF244A	
Q5					BC214LC	AX
Q6					BC184LC	A
Q7					E112	
Q8,9					BF244A	
Q10					BC214LC	AX
Q11,12					BC184LC	**
Q13-19					BC184LC	A
IC1-4					LF356H	
IC5					SN72741P	

7.8 components on SC rear panel section

RV1	1k, 2f NULL potentiometer				94PM	
SW1	SINETRAC/ANALOGUE CORRELATION switch				5.0107.00003	*
SW2	NORMAL/SIGNAL GATING /DIG CORR switch				5.0107.00006	*

7.9 components not mounted on pcb's (SC versions only)

C	0 $\mu$ 22		100		PMT2R	
C	0 $\mu$ 033		"		"	
C	0 $\mu$ 1		30		disc ceramic	

circuit ref	component value	tol %	volts wkg	power rtg.W	type	grade
7.10	<u>dpm display board</u> (D versions only)					
R16	300	5		$\frac{1}{2}$		
R17	1k	"		$\frac{1}{8}$		
R18	220	"		$\frac{1}{2}$		
R19	68	"		"		
IC10						5052-7636
IC11-13						5052-7633
IC14-16						9368
7.11	<u>adc board</u> (D versions only)					
R1	560k	5		$\frac{1}{2}$		
R2	10k	1		$\frac{1}{4}$		
R3	1k1	"		"		
R4	100k	"		"		
R5	1k	"		"		
R6,7	47k	"		"		
R8	5k1	5		$\frac{1}{8}$		
R9	4k7	"		"		
R10	10k	"		"		
R11	4k7	"		"		
R12	51k	"		"		
R13	4k7	"		"		
R14	10k	"		"		
R15	SIT					
RV1	22k					90H
RV2	100					68W
C1,2	47 $\mu$		16		electrolytic	
C3	0 $\mu$ 033		400		MKP10	
C4	10 $\mu$		50		wet tantalum	
C5,6	2 $\mu$ 2		63			
C7	1 $\mu$		100			
C8	0 $\mu$ 01		400			
C9	300p	5			S/M radial	
C10	0 $\mu$ 1		30		disc ceramic	
C11	10 $\mu$		20		tantalum	
C13,14	0 $\mu$ 1		30		disc ceramic	
C15	1 $\mu$		100			
C16	0 $\mu$ 01				disc ceramic	
C17	1 $\mu$		100			
C18	10 $\mu$		20		tantalum	
C19	470p		400		TFF	
C20	47 $\mu$		10		electrolytic	
C21	4700p		400		TFF	
C22	0 $\mu$ 1		30		disc ceramic	
C23	1000 $\mu$		35		electrolytic	
D1,2						1N4148
D3						W04

circuit ref	component value	tol %	volts wkg	power rtg.W	type	grade
IC1					8052 CPD	
IC2					LF355N	
IC3					7101CPL	
IC4					555	
IC5					SN74LS123N	
IC6					SN74LS51N	
IC7					SN74LS368N	
IC8,9					SN74LS367N	
7.12	<u>components not on pcb's (D versions)</u>					
RV1	1M				SAMPLE PERIOD	*
SW1	MIN, NORMAL, SLOW switch				5.0107.00006	*
SW2	FILTER, IN/OUT switch				5.0107.00003	*
T1	transformer				4.0910.21027	*
M1	analogue, edge meter				4.1011.31018	*
M2	digital panel meter					*
BR1	voltage regulator					*
7.13	<u>1f option, mod 10</u>					
C1,2	22μ		63		TFM	
7.14	<u>12dB/octave option, mod 13</u>					
additional on ref/demod board:						
R152	2M2	5				
R153	22M	"				
VR23	22k				90H	
IC17					μA356TC	
additional on time constant switch:						
R11	47k	5		$\frac{1}{8}$		
C111	4μ7	5	100		TFM	
C112	1μ5	"	"		"	
C113	0μ47	"	"		"	
C114	0μ15	"	160		"	
C115	0μ047	"	400		"	
C116	0μ015	"	"		"	
C117	4700p	"	"		TFF	
C118	1500p	"	"		"	
C119	470p	"	"		"	
C120	47p	"	"		"	
SW1	6/12 dB/octave switch				5.0103.00004	*

circuit ref	component value	tol %	volts wkg	power rtg.W	type	grade
7.15	<u>demodulator monitor option, mod 14</u>					
R1	10k	1				
R2	33k	"				
R3	20k	"				
R4	33k	"				
R5	1k3	5				
R6	3k	"				
R7	47k	1				
R8	1k	5		1/2		
R9	36k	"				
R10	4k7	"				
R11	10k	"				
R12,13	510	1				
R14	5k1	5				
R15	10k	"				
R16-18	1k	1				
RV1	1k				90V	
RV2	22k				"	
RV3	10k				"	
C1,2	3μ3		100		TFM	
C3	10p					
C4	SIT					
C5	220p				S/M radial	
C6	1000p				TFF	
C7-9	0μ1				disc ceramic	
C10,11	100μ		16		CSB	
CV1,2	1p4-5p5					
Q1,2					FM13	**
Q3,4					TM2	**
Q5					BC184LC	A
Q6,7					TM2	
IC1					LM318	
IC2,3					LF356	

\* Items marked thus should be obtained from Brookdeal Electronics Ltd. since they are either selected versions of parts available from other manufacturers or are specially made to Brookdeal designs. When ordering such parts, please quote instrument type, serial number and circuit reference.

\*\* Specially matched versions

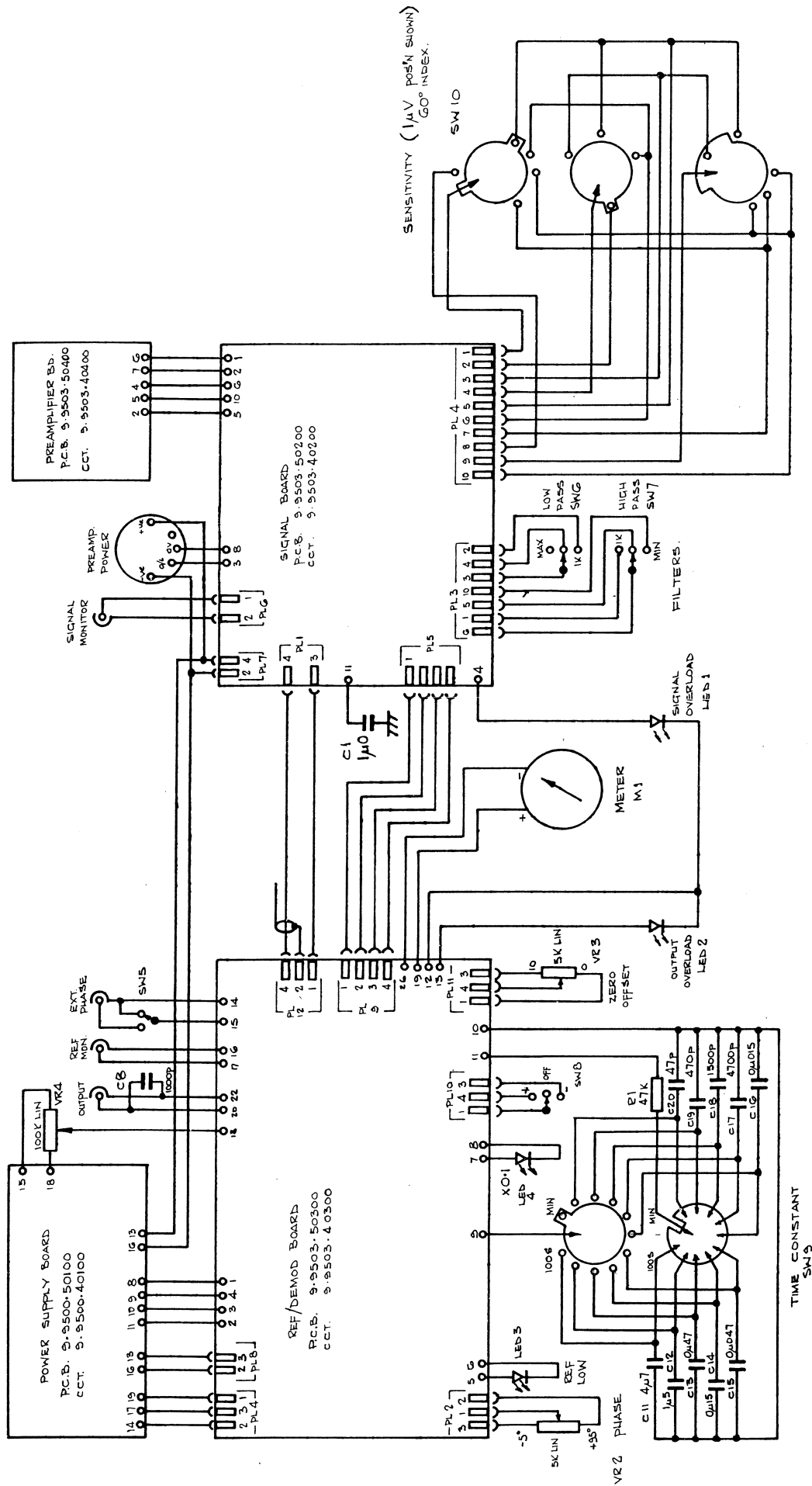

figure 8 switching and wiring diagram (9503)

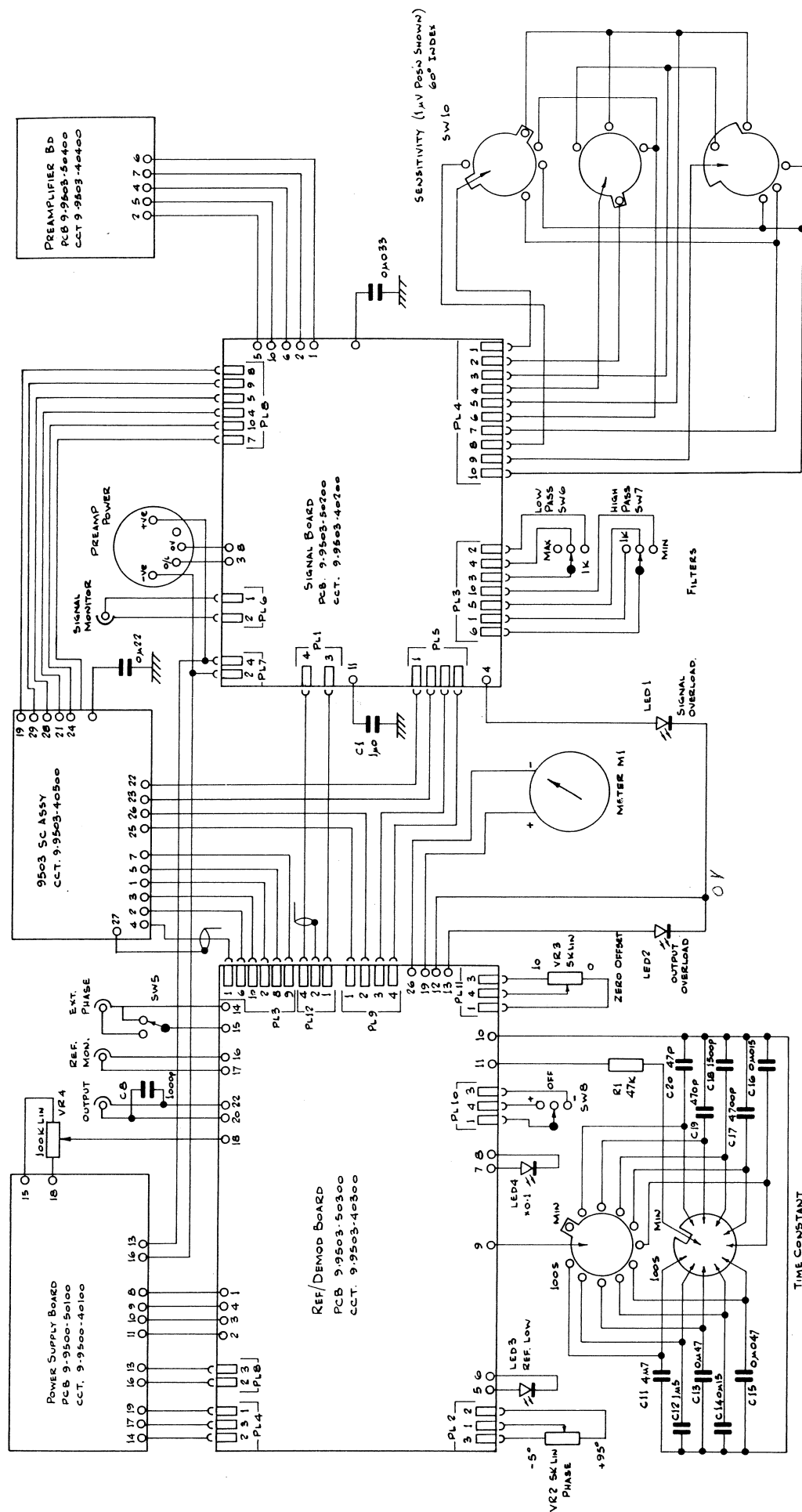

figure 9 switching and wiring diagram (9503SC)

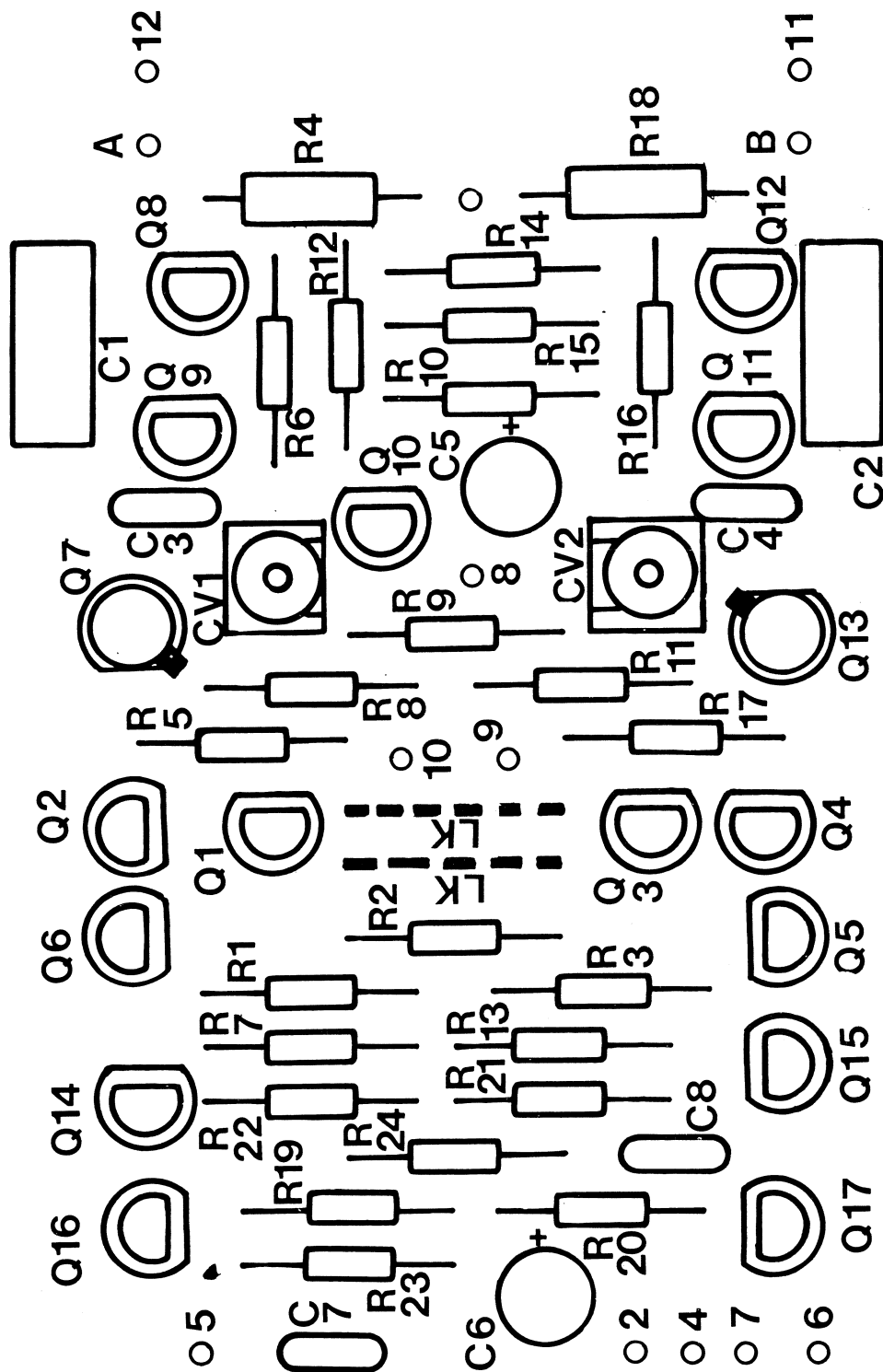

fig 10(a) preamplifier board component layout



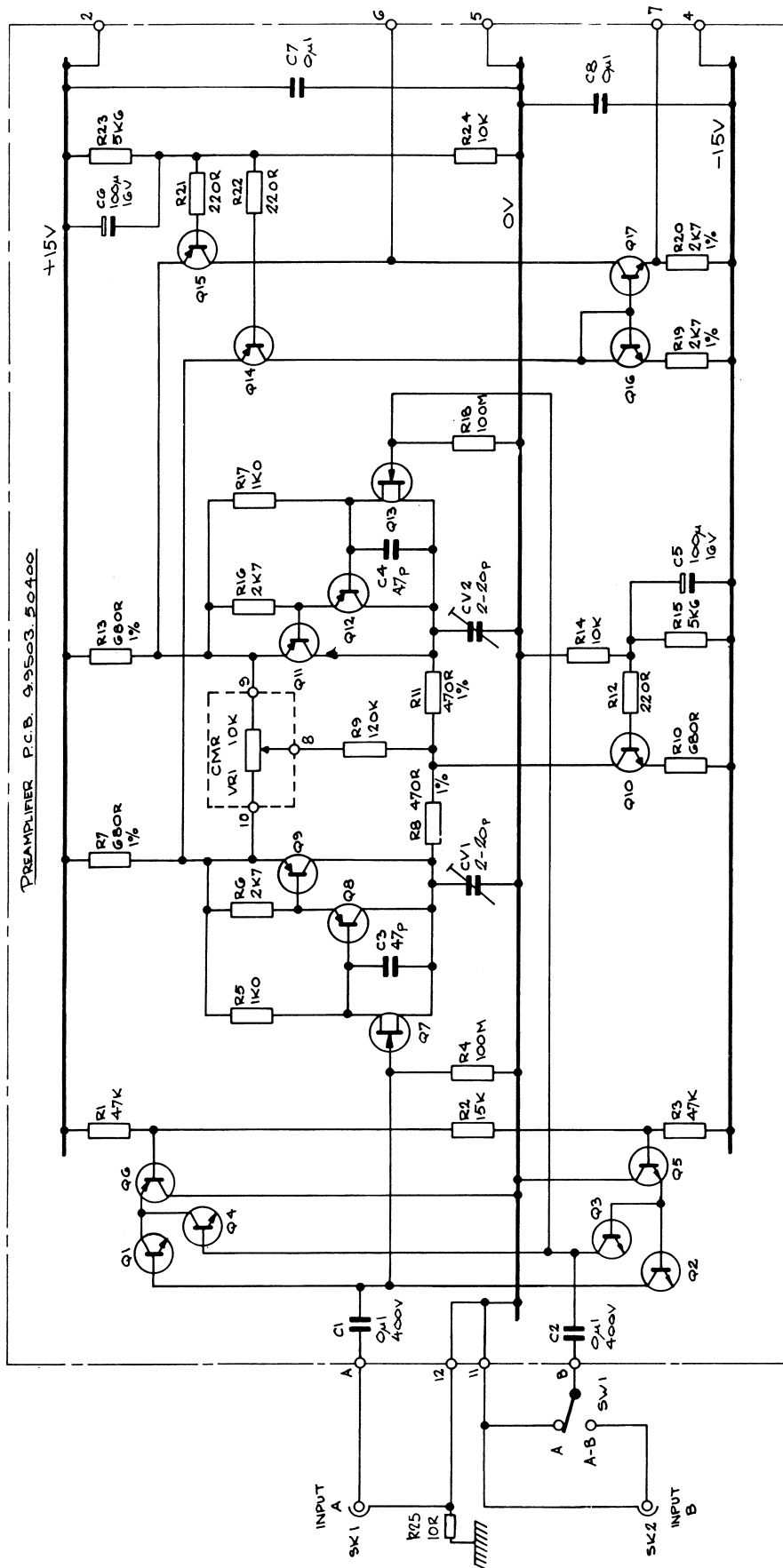
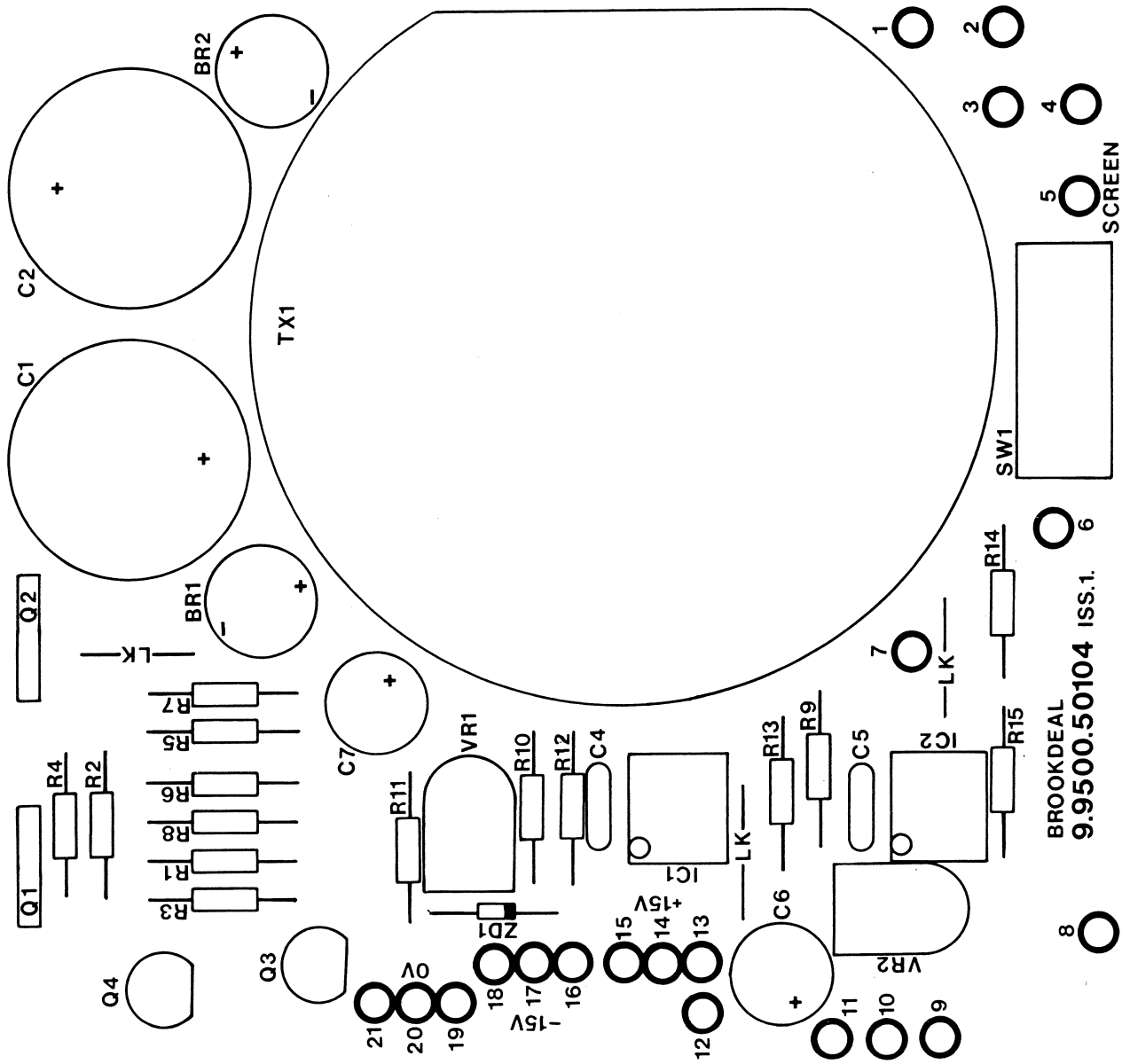
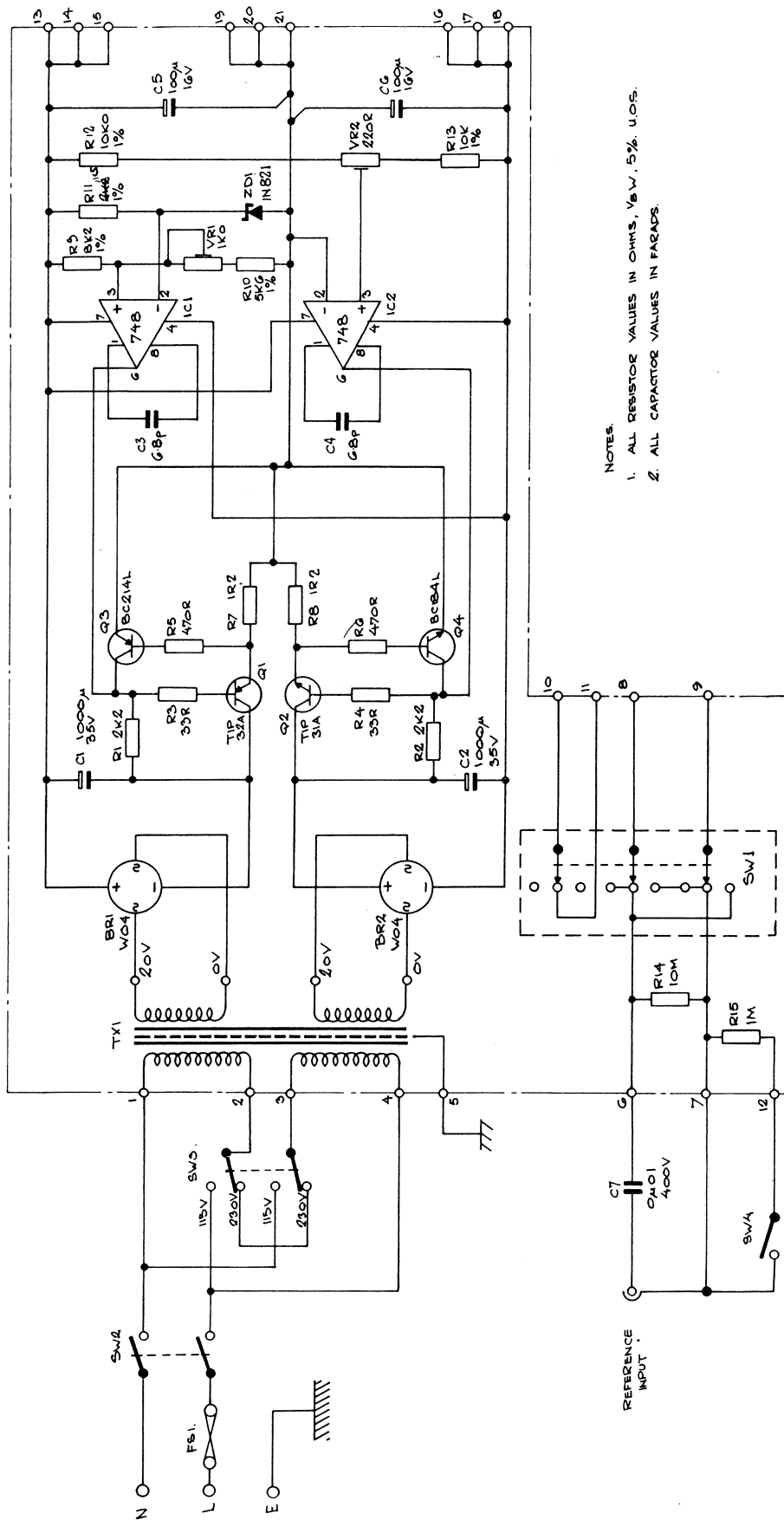

fig 10(b) preamplifier board circuit diagram



BROOKDEAL  
9.9500.50104 ISS.1

fig 11(a) power supply board component layout



NOTES

1. ALL RESISTOR VALUES IN OHMS, V.W. 5% U.O.S.
2. ALL CAPACITOR VALUES IN FARADS.

fig 11(b) power supply board circuit diagram

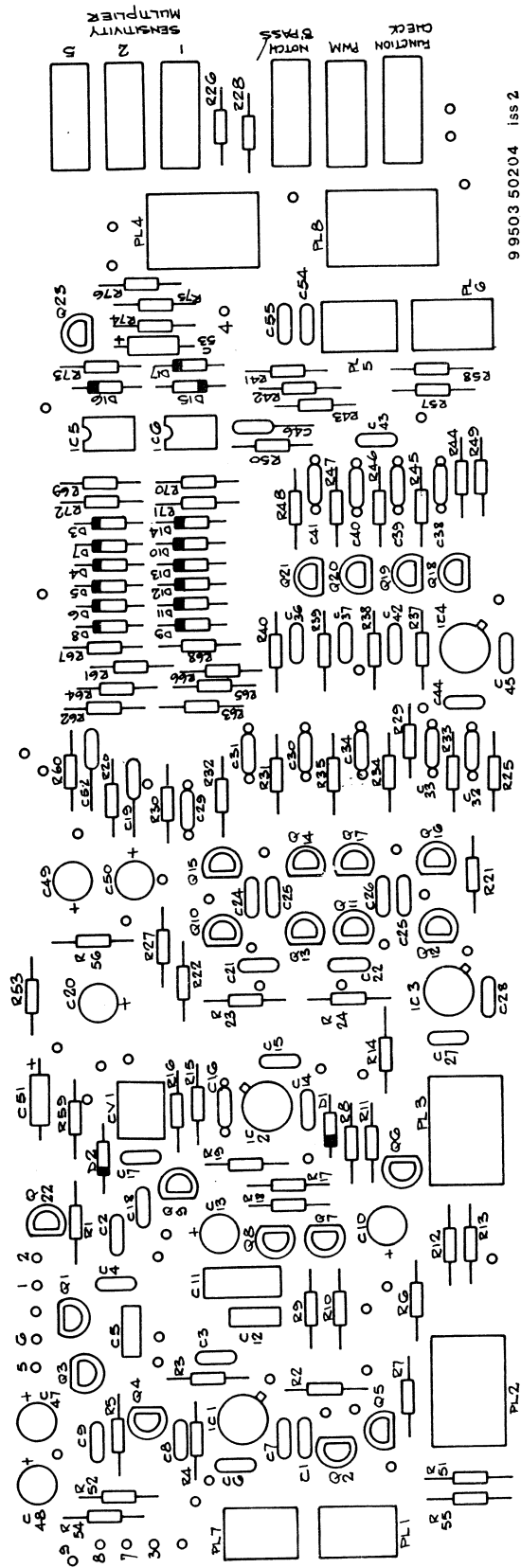

9 9503 50204 iss 2

fig 12(a) signal channel board component layout

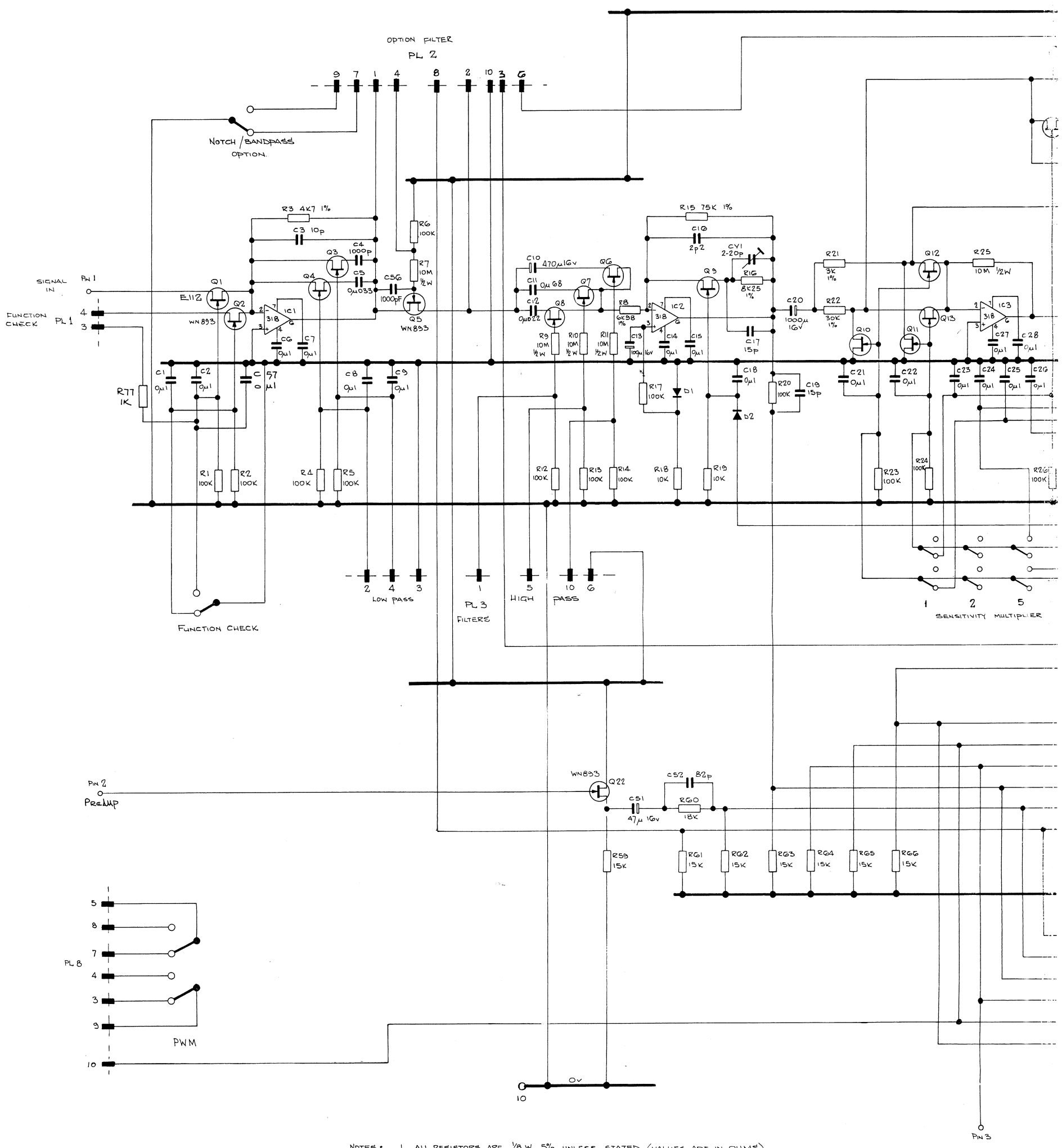

- NOTES:
1. ALL RESISTORS ARE 1/8 W 5% UNLESS STATED. (VALUES ARE IN OHMS)
  2. ALL CAPACITOR VALUES IN FARADS.
  3. ALL F.E.T.'S ARE E112 UNLESS STATED.
  4. IC1-IC3 PIN 7 TO +Vc RAIL  
PIN 4 TO -Vc RAIL
  5. ALL DIODES IN 4148.

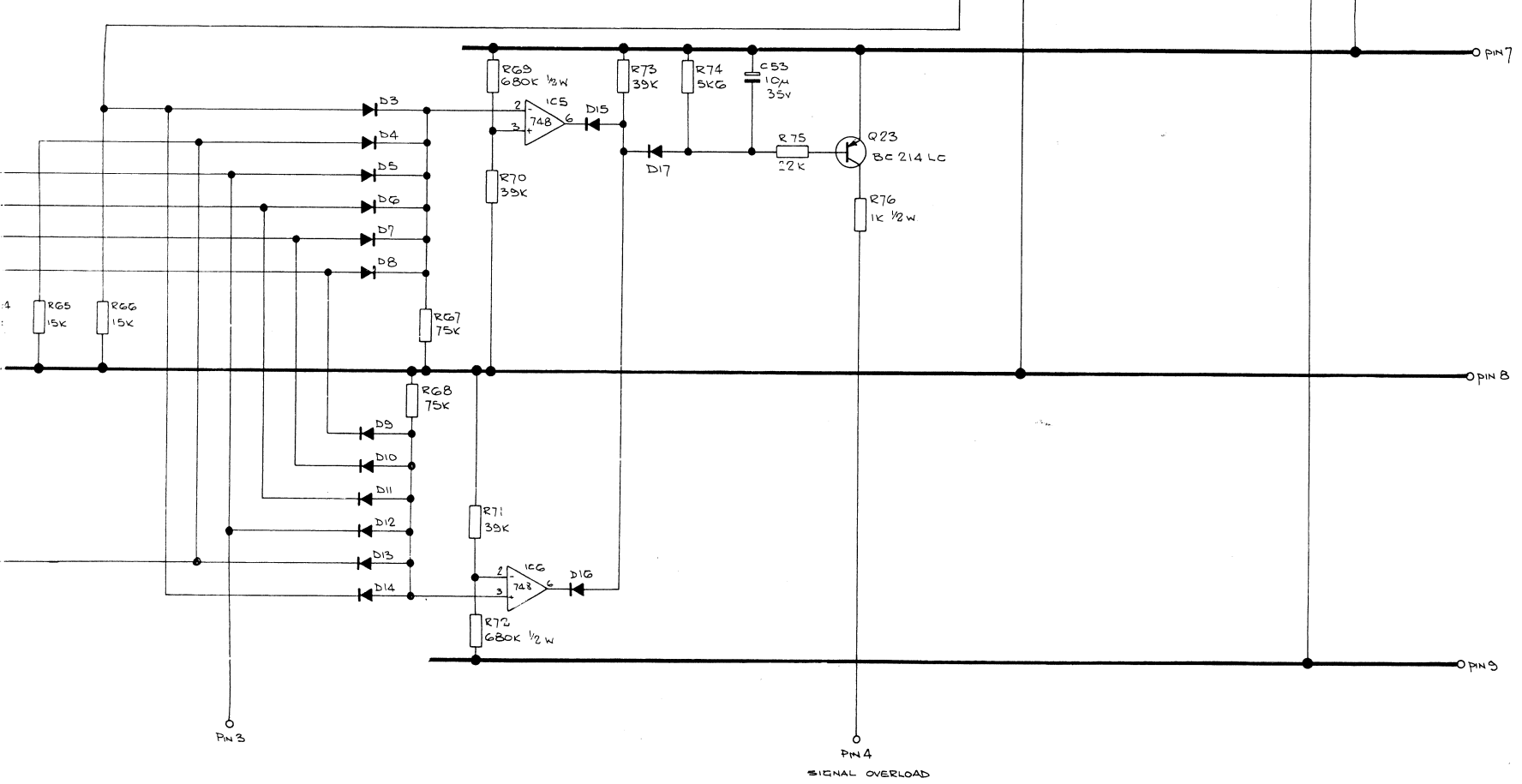
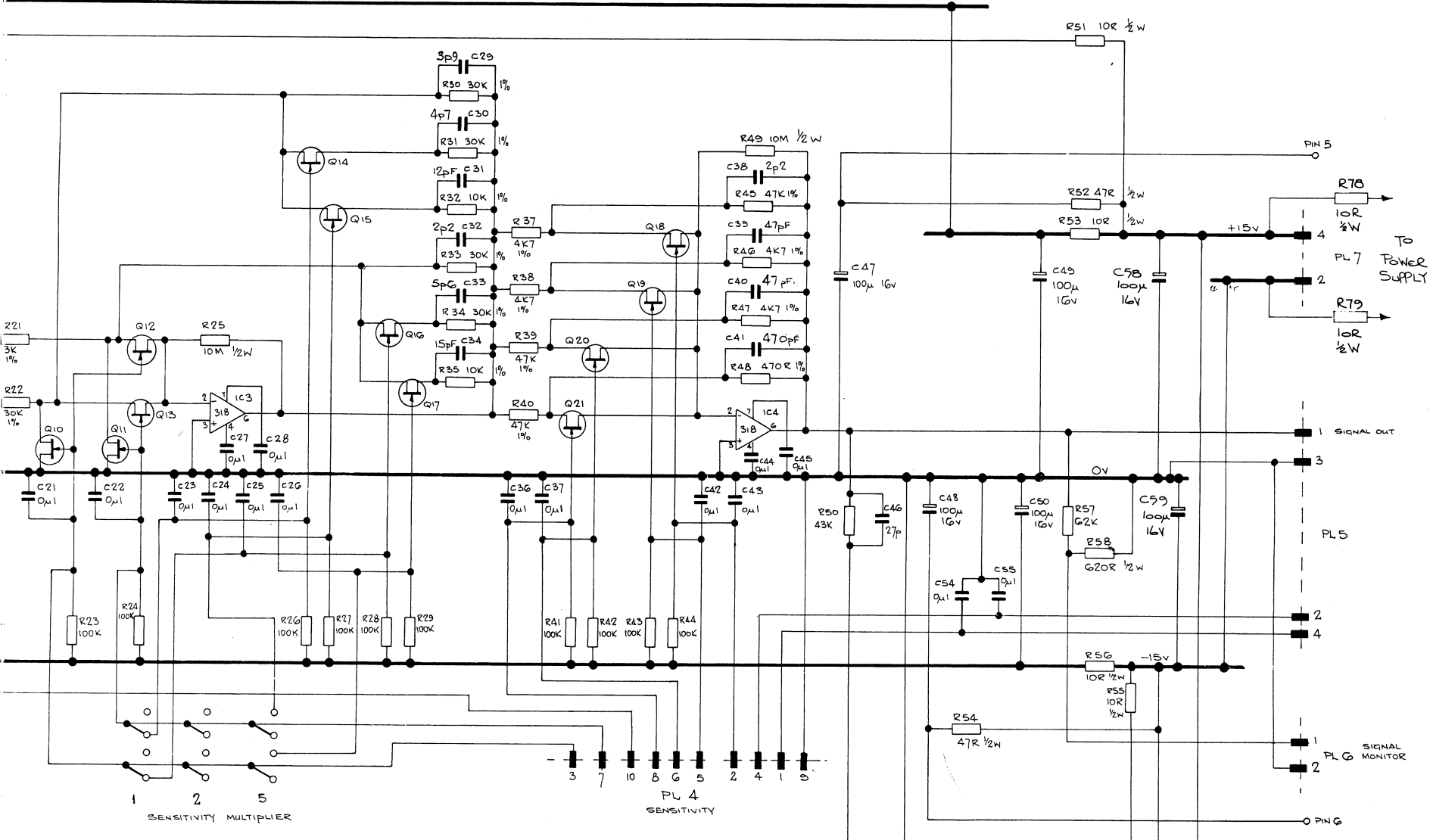

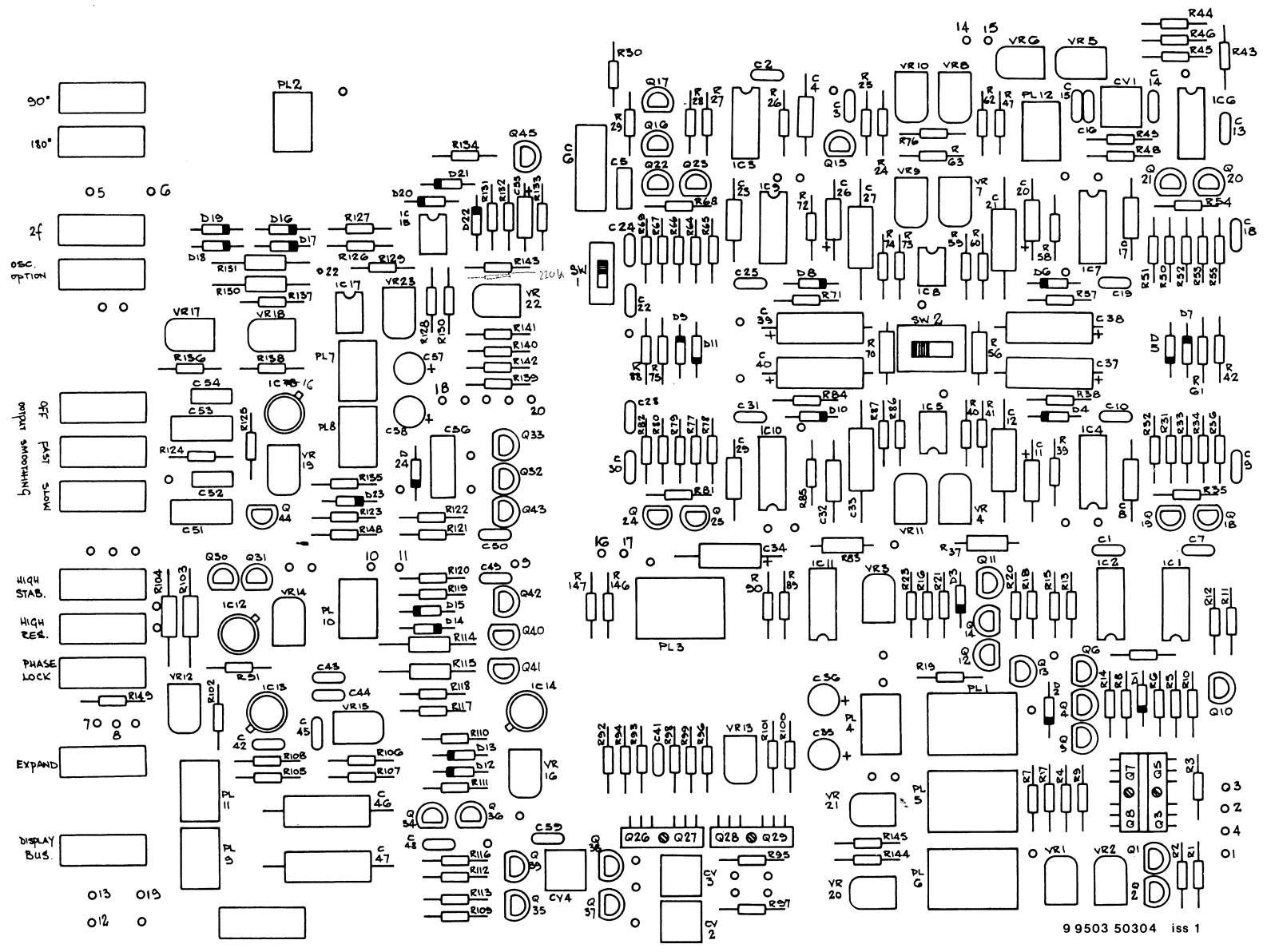

fig 13(a) reference/demodulator board component layout

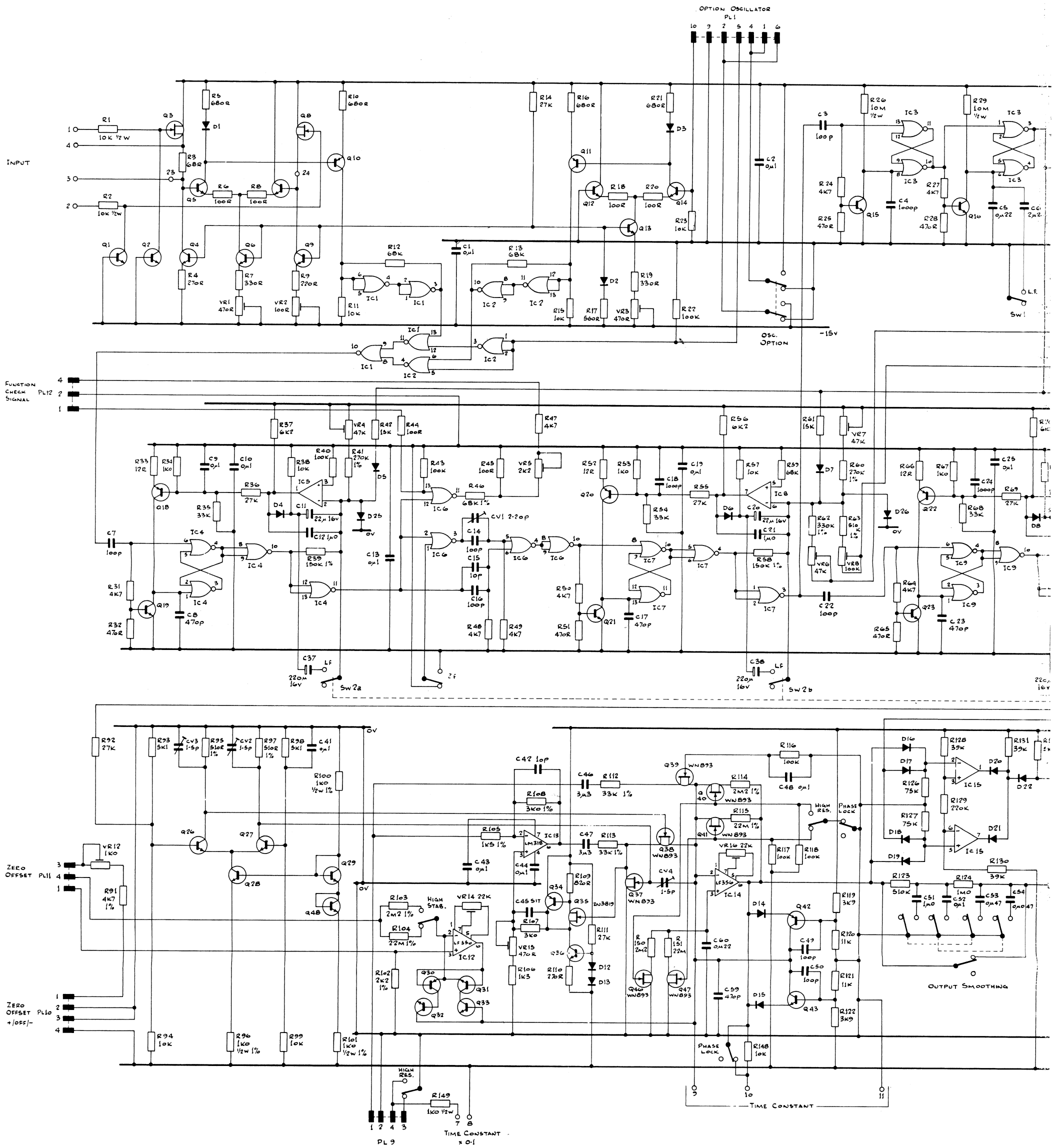
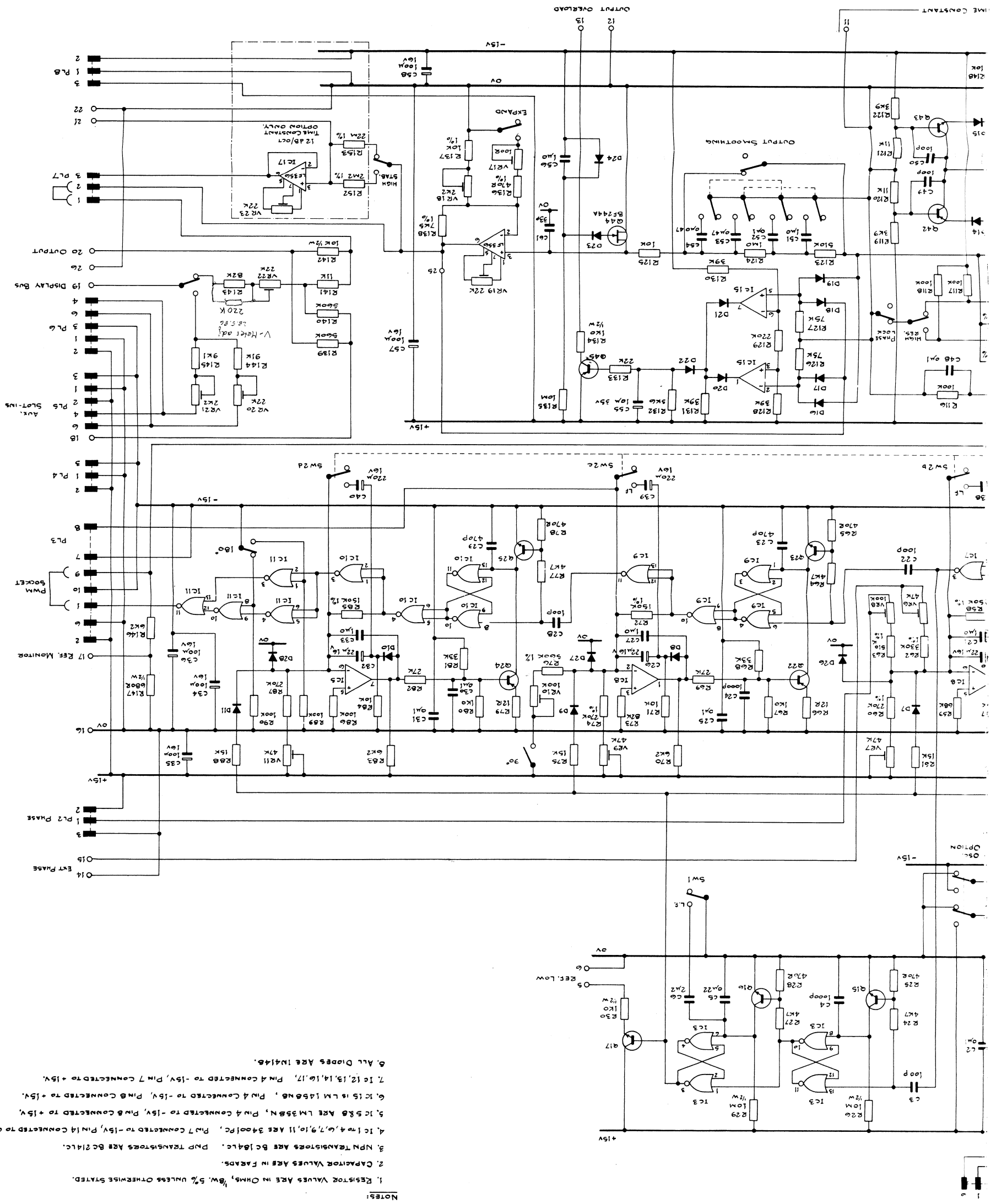

fig 13(b) reference/demodulator board circuit dia





NOTES:

1. RESISTOR VALUES ARE IN OHMS, SW. 5% UNLESS OTHERWISE STATED.
2. CAPACITOR VALUES ARE IN FARADS.
3. NPN TRANSISTORS ARE BC104/C. PNP TRANSISTORS ARE BC214/C.
4. IC1, 4, 6, 7, 9, 10, 11 ARE 3400/PC. P1, 7 CONNECTED TO -15V, P14 CONNECTED TO 0V.
5. IC5, 8 ARE LM358/N. P1, 4 CONNECTED TO -15V, P16 CONNECTED TO +15V.
6. IC15 IS LM1458/N. P1, 4 CONNECTED TO -15V, P16 CONNECTED TO -15V.
7. IC12, 13, 14, 16, 17, P1, 4 CONNECTED TO -15V, P1, 7 CONNECTED TO +15V.
8. ALL DIODES ARE 1N4148.

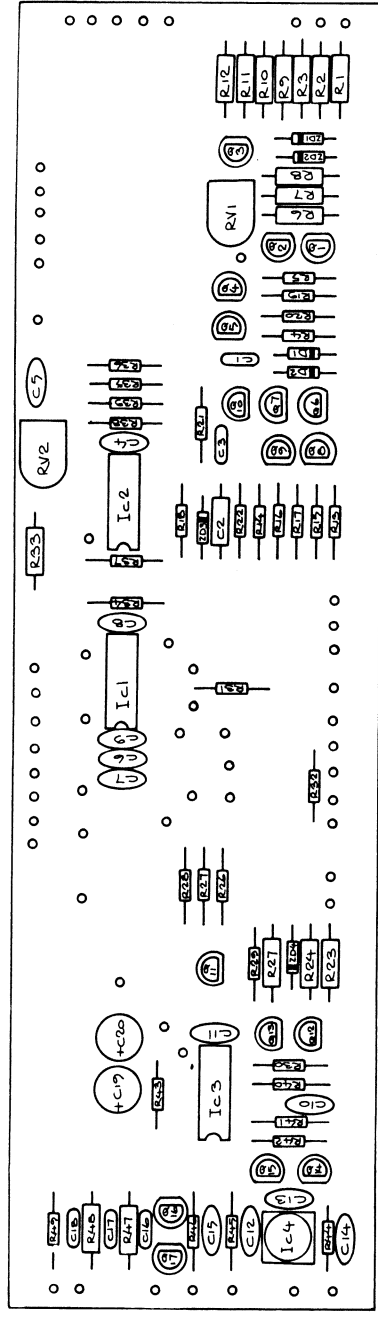

fig 14(a) correlation board (C & SC versions)  
component layout

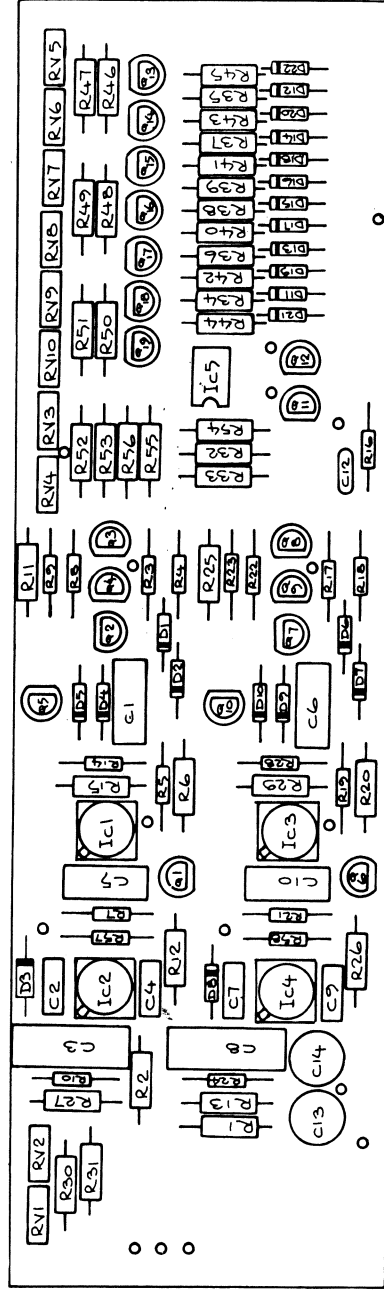

fig 14(b) sinetrac board (SC versions)  
component layout

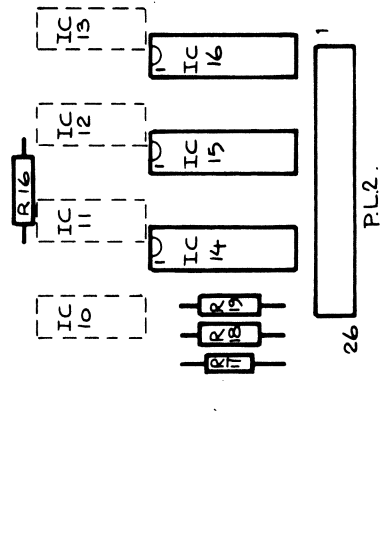

fig 15(a) dpm display board (D versions) component layout

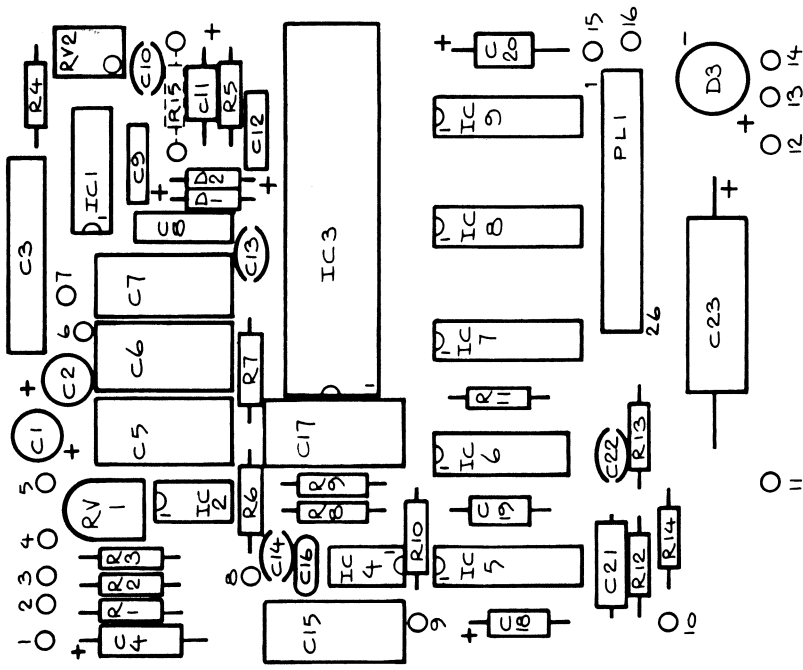
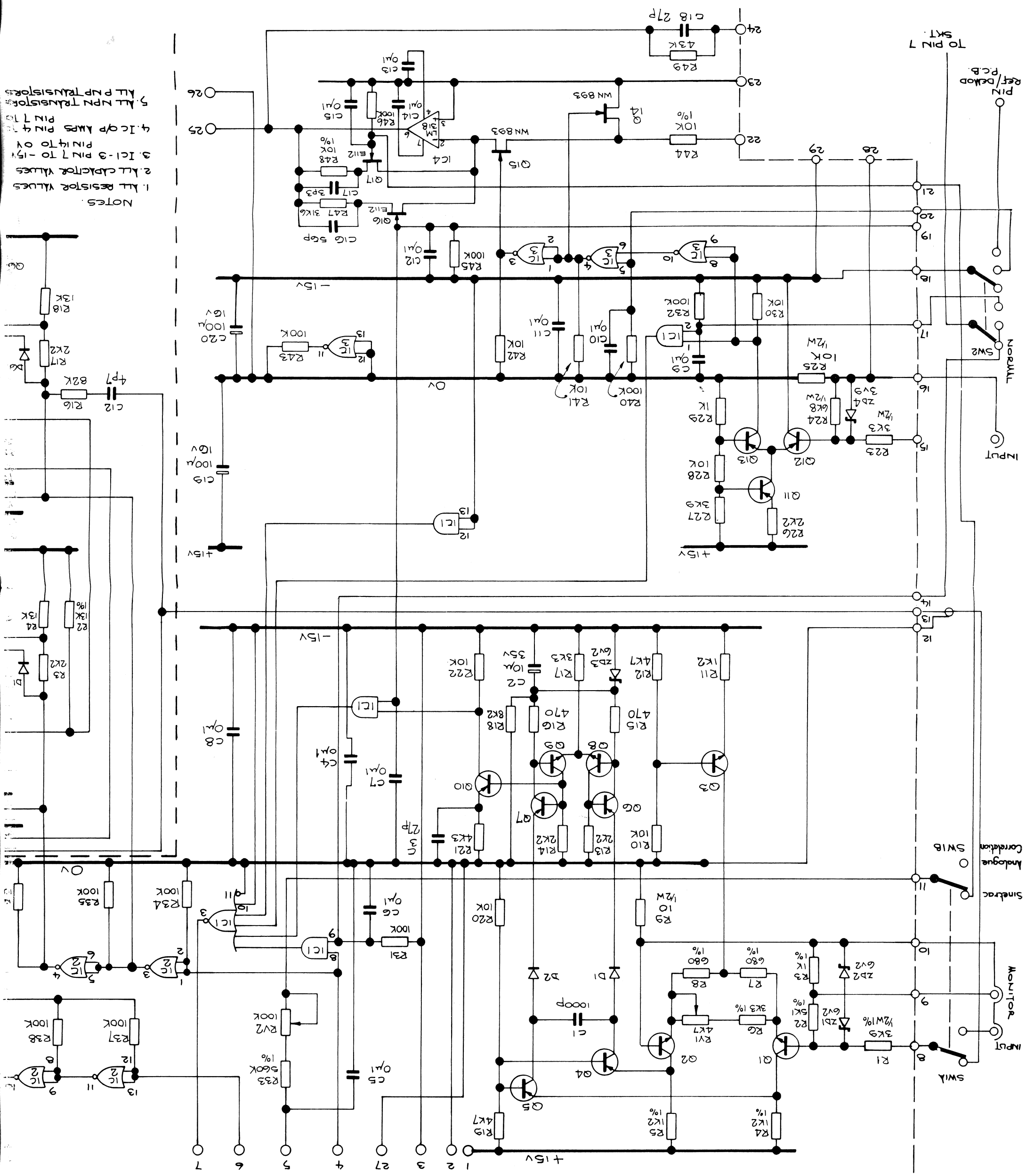
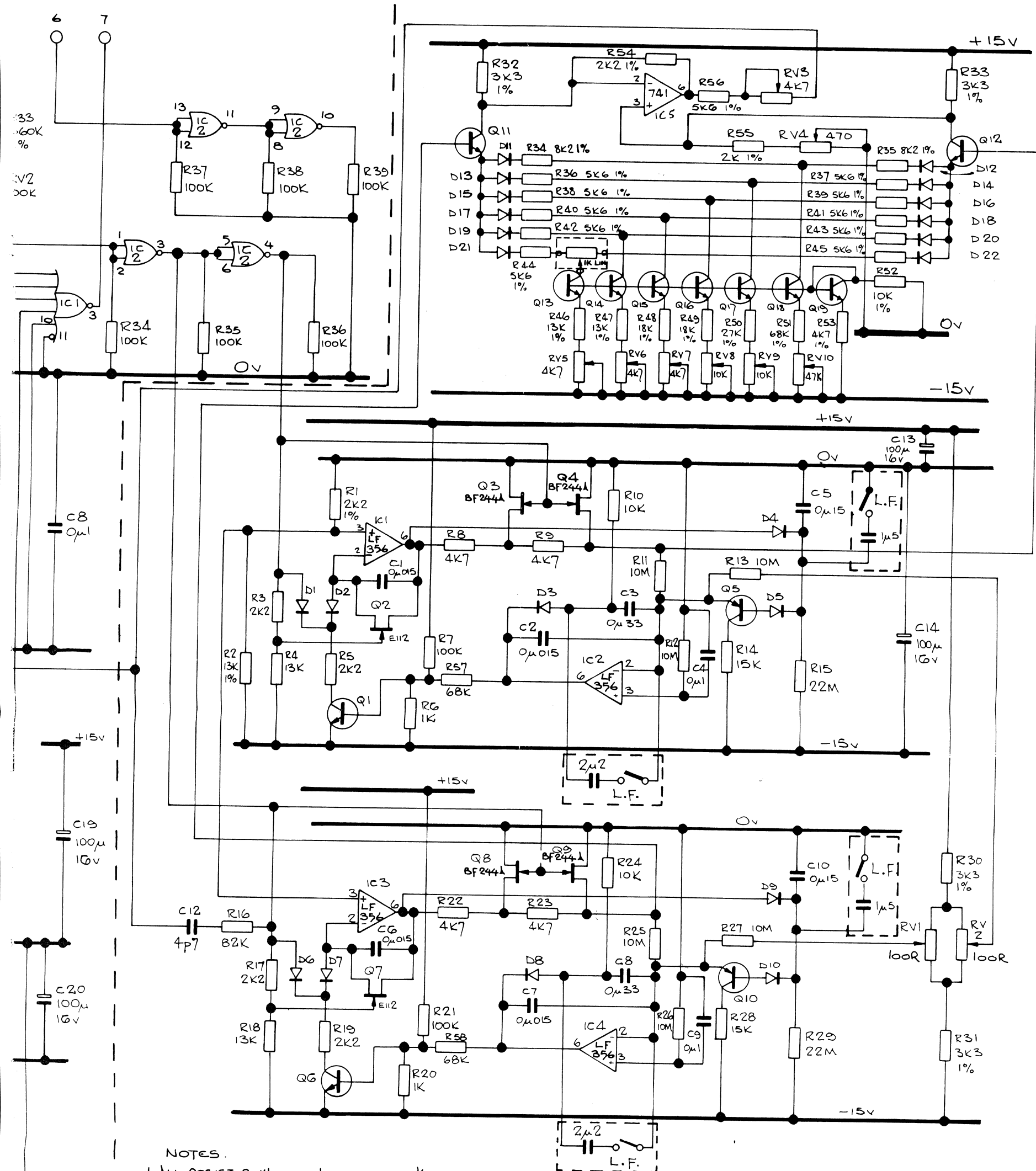

fig 15(b) adc board (D versions) component layout



- NOTES:
1. ALL RESISTOR VALUES
  2. ALL CAPACITOR VALUES
  3. IC1-3 PIN 7 TO -15V
  4. IC OP AMPS PIN 4 TO -15V
  5. ALL PNP TRANSISTORS



- NOTES.
1. ALL RESISTOR VALUES ARE IN OHMS,  $\frac{1}{2}$ W, 5% U.O.S.
  2. ALL CAPACITOR VALUES ARE IN FARADS.
  3. IC1-3 PIN 7 TO -15V  
PIN 14 TO 0V
  4. IC 4 P AMPS PIN 4 TO -15V  
PIN 7 TO +15V
  5. ALL NPN TRANSISTORS ARE BC 184 LC  
ALL PNP TRANSISTORS ARE BC 214 LC

ation & sinetrac circuit diagram

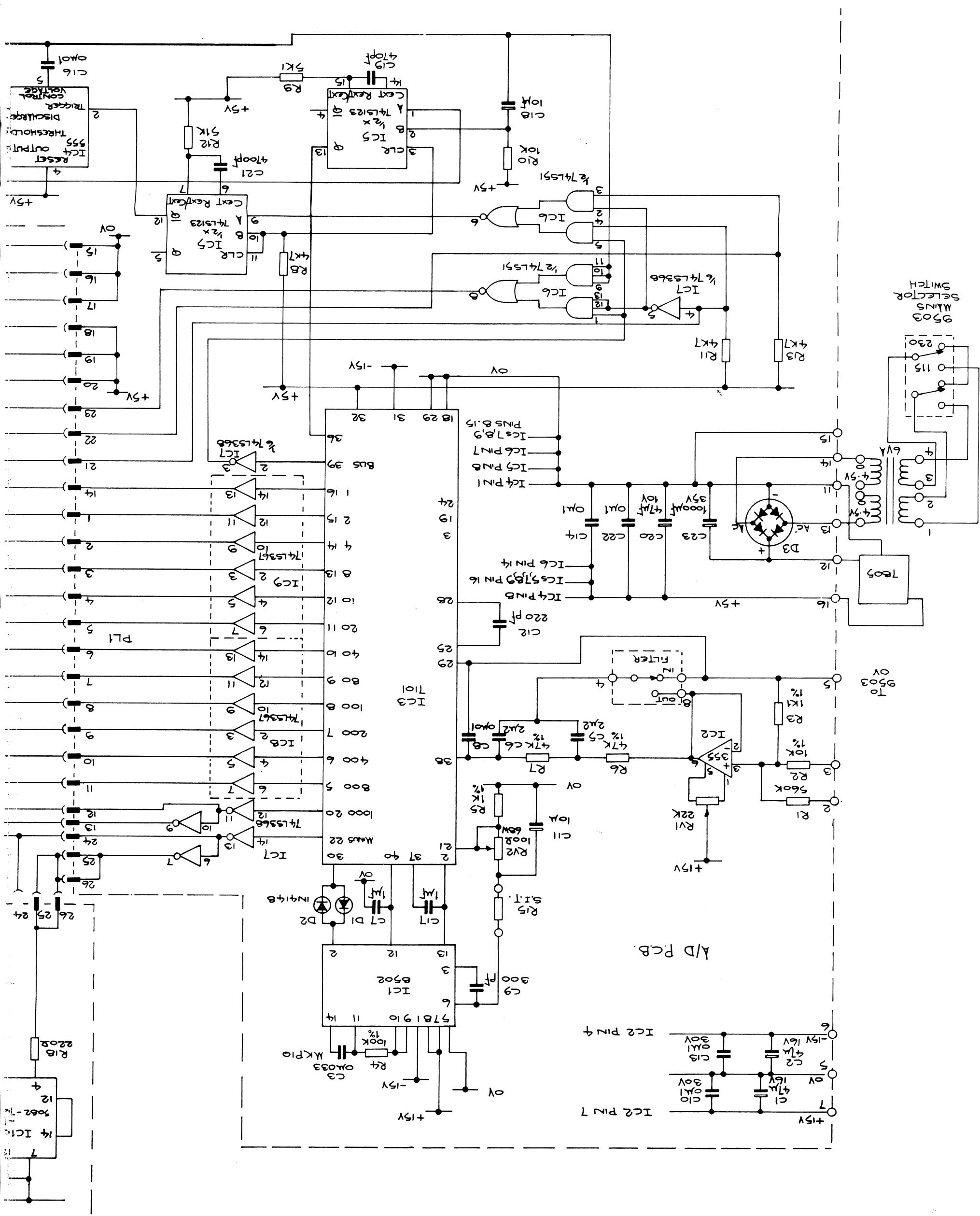

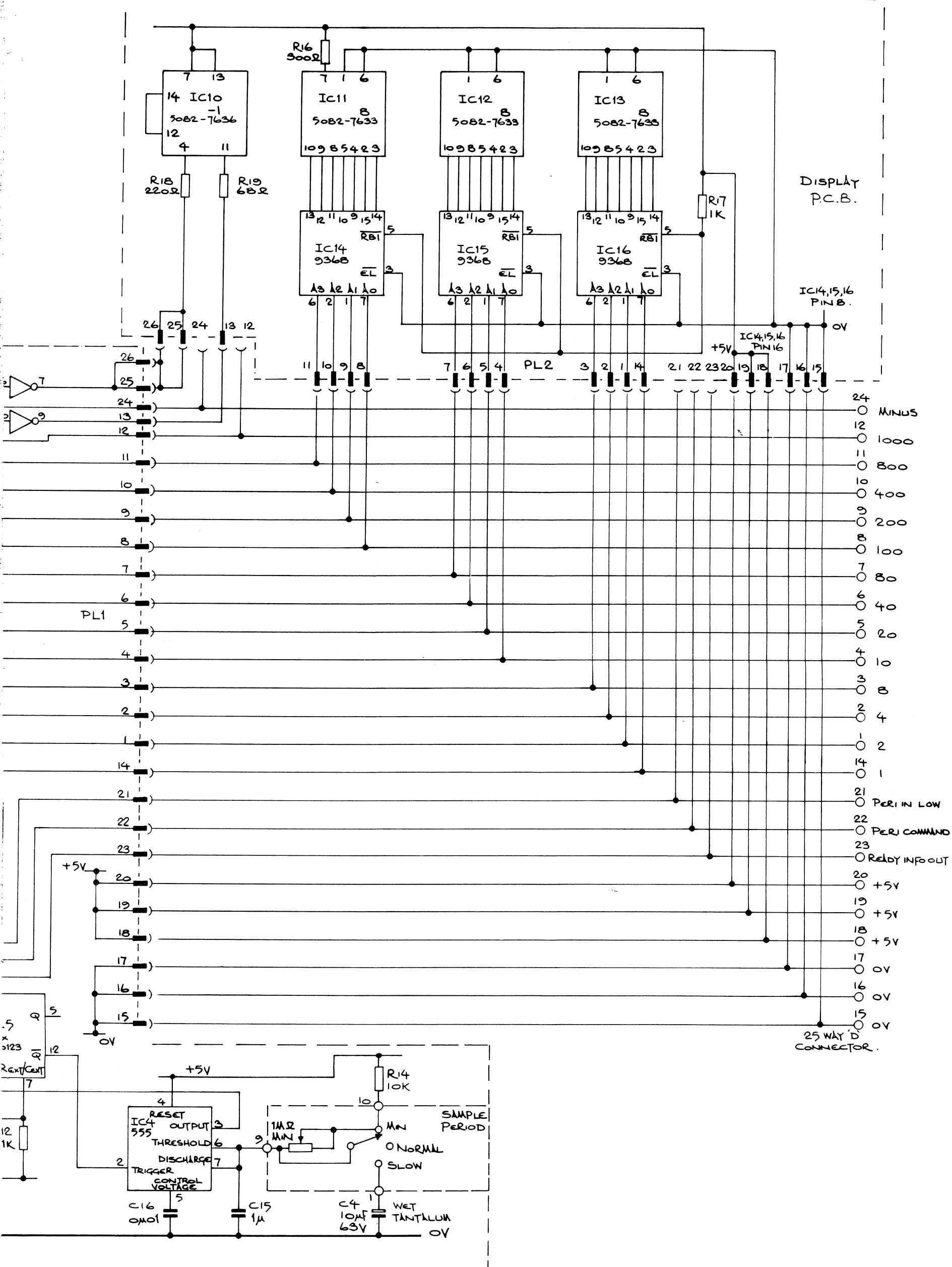

ital models, circuit diagram

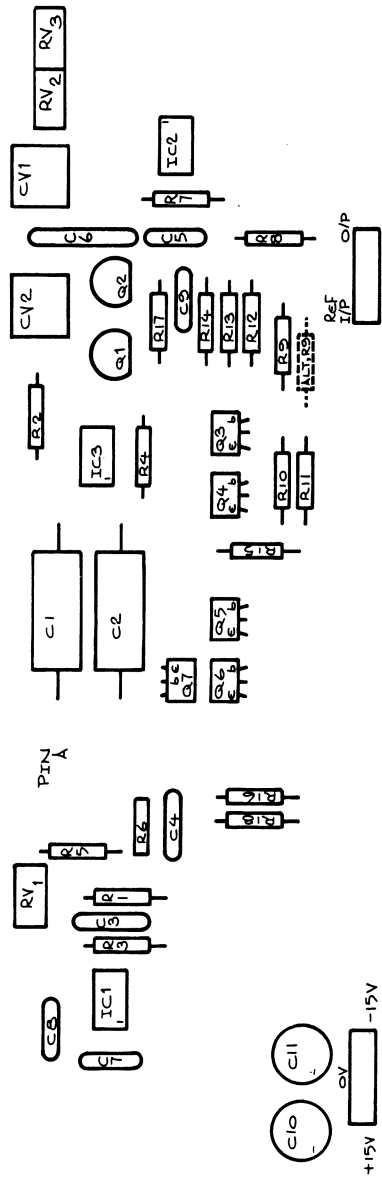

figure 16(a) demodulator monitor (mod 14) component layout

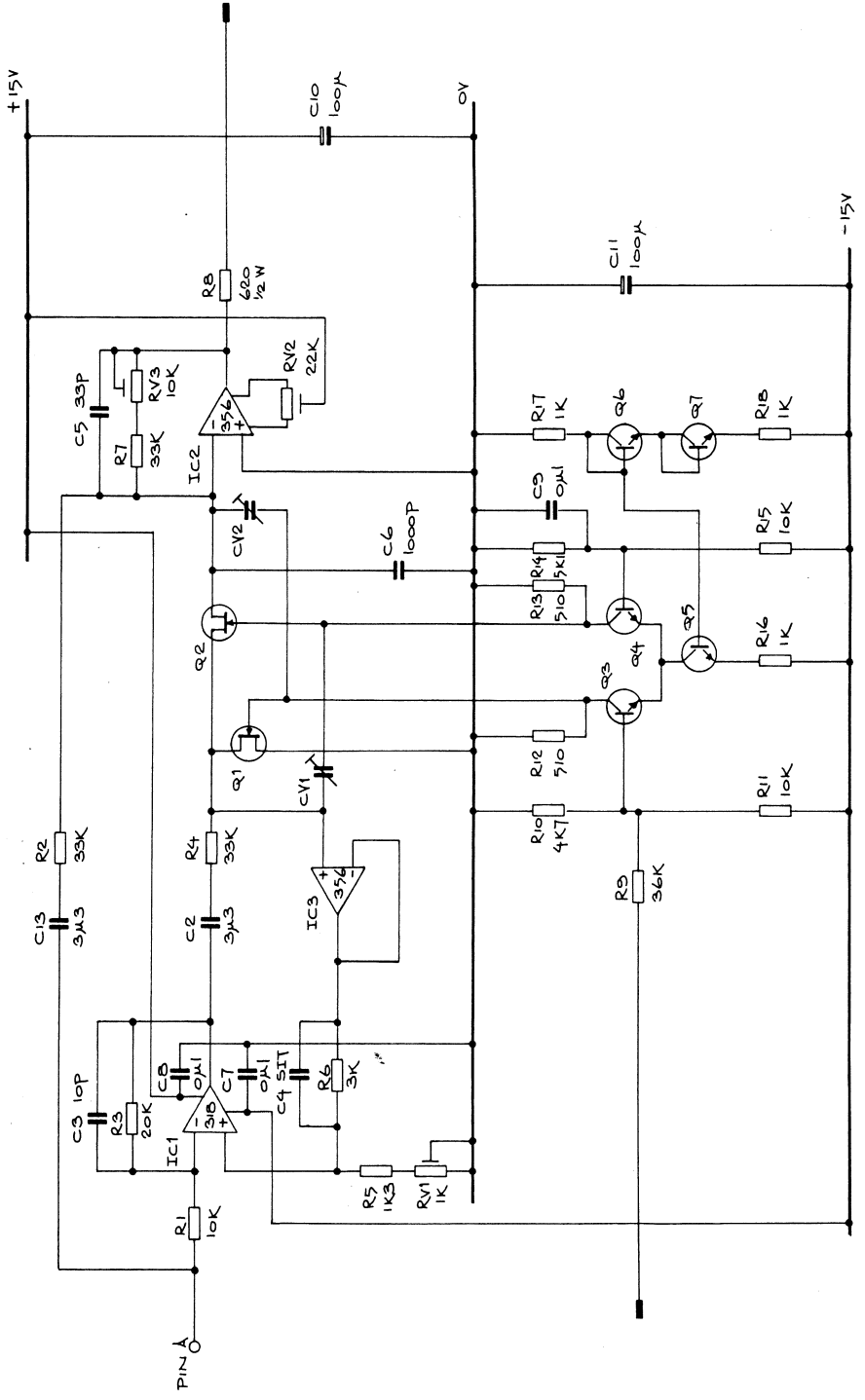

figure 16(b) demodulator monitor (mod 14) circuit diagram